

## GRF5618

### HIGH LINEARITY POWER AMPLIFIER 1805 to 1915 MHz

#### FEATURES

- Excellent OP1dB, OIP3, ACLR and IM3 Performance
- Native Linearity Provides up to +26 dBm P<sub>OUT</sub> with 45 dBc ACLR – Without the Need for Digital Predistortion Correction
- +26 dBm Linear Output Power Maintained at 85 °C
- Flexible Biasing Provides Latitude for Linearity Optimization
- 365 mA Native Mode Quiescent Current Consumption
- 5 V Supply Voltage
- 50 Ω Single-ended Input and Output Impedances
- Digital Shutdown
- Rugged Design is Extremely Resilient to Mismatched Loads
- -40 to 85 °C Operating Temperature Range
- Compact 3 x 3 mm QFN-16 Package

#### Reference: 5 V / 365 mA I<sub>CCQ</sub> / 1880 MHz

- Gain: 25.1 dB
- OIP3: 48 dBm at 25 dBm P<sub>OUT</sub>/tone
- OP1dB: 34.9 dBm
- Evaluation Board Noise Figure: 4.4 dB

#### APPLICATIONS

- Cellular Boosters
- Automotive Compensators
- Picocells/Femtocells
- Customer Premise Equipment

#### DESCRIPTION

The GRF5618 is a high gain, two-stage InGaP HBT Power Amplifier designed to deliver excellent P1dB, ACLR and IM3 performance over the 1805 to 1915 MHz band. Its exceptional native linearity makes it an ideal choice for transmitter applications that typically do not employ digital predistortion correction schemes.

This device is part of a complete family of externally matched linear amplifiers that cover the following frequency ranges:

GRF5605: 617 - 652 MHz	GRF5610: 860 - 928 MHz
GRF5606: 663 - 716 MHz	GRF5611: 902 - 960 MHz
GRF5607: 703 - 748 MHz	GRF5616: 1625 - 1675 MHz
GRF5608: 729 - 830 MHz	GRF5617: 1710 - 1785 MHz
GRF5609: 814 - 862 MHz	GRF5618: 1805 - 1915 MHz

Please consult with the GRF applications engineering team for custom tuning/evaluation board data.

#### BLOCK DIAGRAM

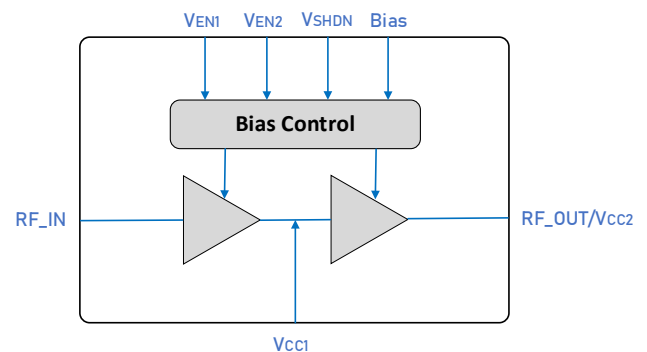

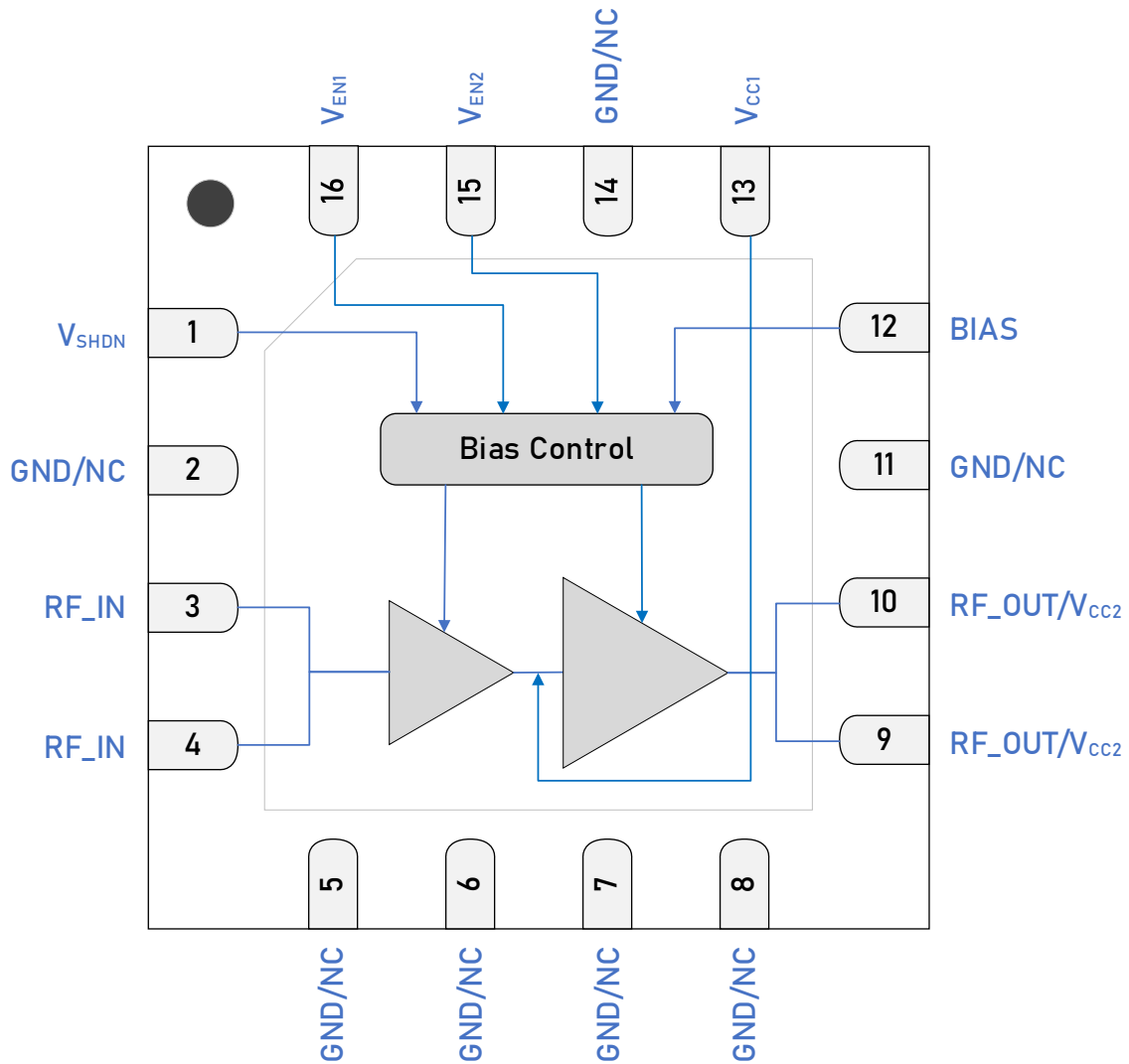

3 x 3mm QFN-16 Pin Out (Top View)

## Pin Assignments

Pin	Name	Description	Note
1	V <sub>SHDN</sub>	Digital Shutdown Pin	V <sub>SHDN</sub> ≥ 1.8 V (Logic HIGH) disables device. V <sub>SHDN</sub> ≤ 0.8 V (Logic LOW) enables device.
2, 5, 6, 7, 8, 11, 14	GND/NC	Ground or No Connect	No internal connection to die. These pins can be left unconnected, or be connected to ground (recommended). Use a via as close to the pin as possible if grounded.
3, 4	RF_IN	RF Input	Pins 3 & 4 tied together on system board. An external DC blocking cap must be used.
9, 10	RF_OUT/V <sub>CC2</sub>	PA Output/Bias Voltage	Pins 9 & 10 tied together on system board. V <sub>CC2</sub> must be applied to this pin via an RF choke.
12	Bias	Bias Circuit Supply	Connect to V <sub>CC2</sub> through external resistor.
13	V <sub>CC1</sub>	Bias Voltage	Connect to V <sub>CC1</sub> through external inductor (or 0 Ω resistor) with capacitive termination above (see application schematic).
15	V <sub>EN2</sub>	Enable2 Voltage Input	V <sub>EN2</sub> and series resistor set I <sub>CCQ</sub> for the output stage. V <sub>EN2</sub> ≤ 0.2 volts disables stage 2.
16	V <sub>EN1</sub>	Enable1 Voltage Input	V <sub>EN1</sub> and series resistor set I <sub>CCQ</sub> for the input stage. V <sub>EN1</sub> ≤ 0.2 volts disables stage 1.
PKG BASE	GND	Ground	Provides DC and RF ground for the amplifier, as well as thermal heat sink. Recommend multiple 8 mil vias beneath the package for optimal RF and thermal performance. Refer to evaluation board top layer graphic on schematic page.

## Truth Table

Pin	Logic	Condition
V <sub>SHDN</sub>	LOW	Full Operation
	HIGH	All Amplifiers Off
V <sub>EN1</sub>	LOW	Stage 1 Amplifier Off
	HIGH	Stage 1 Amplifier On
V <sub>EN2</sub>	LOW	Stage 2 Amplifier Off
	HIGH	Stage 2 Amplifier On

## Absolute Ratings

Parameter		Symbol	Min.	Max.	Unit
Supply Voltage		$V_{CC}$	3	5.25	V
RF Input Power	50 $\Omega$ , $V_{CC} = 5$ V, CW Tone, 100% Duty Cycle, $T_{PKG\ BASE} = 25$ °C.	$P_{IN\ MAX - 1:1}$		20	dBm
	Load VSWR $\leq 8:1$ , all phase angles, $V_{CC} = 5$ V, CW Tone, 100% Duty Cycle, $T_{PKG\ BASE} = -40$ to 85 °C.	$P_{IN\ MAX - 8:1}$		TBD	
Operating Temperature (package base).		$T_{PKG\ BASE}$	-40	85	°C
Maximum Junction Temperature (MTTF > 10 <sup>6</sup> hours).		$T_{J\ MAX}$		190	°C
Maximum Dissipated Power Stage 1: DC only (no RF applied).		$P_{DISS\ MAX}$		* 750	mW
Maximum Dissipated Power Stage 2: DC only (no RF applied).		$P_{DISS\ MAX}$		* 2250	mW
Shutdown Voltage		$V_{SHDN}$		** 5.25	V

## Electrostatic Discharge

Charged Device Model	CDM	TBD		V
Human Body Model	HBM	TBD		V

## Storage

Storage Temperature	$T_{STG}$	-65	150	°C
Moisture Sensitivity Level	MSL		1	--

## Notes:

\* Bias resistance at M5/M9 has been empirically optimized for linearity. Thus, there will be no benefit in decreasing (increasing) resistance ( $I_{CC0}$ ).

\*\* M4 = 0  $\Omega$ .  $I_{SHDN}$  with  $V_{SHDN} = 5.25$  V = 540  $\mu$ A., decreasing linearly to 65  $\mu$ A with nominal (and also minimum)  $V_{SHDN} = 1.8$  V.



**Caution! ESD Sensitive Device.**

**Exceeding Absolute Maximum Rating conditions may cause permanent damage.**

Note: For additional information, please refer to *Manufacturing Note MN-001 — Package and Manufacturing Information*.



All Guerrilla RF products are provided in RoHS compliant lead (Pb)-free packaging requiring no exemptions. Additional information for this topic can be found at this link - *Environmental and Restricted Substance Statement Library*



### Recommended Operating Conditions

Parameter	Symbol	Specification			Unit	Condition
		Min.	Typ.	Max.		
Supply Voltage	V <sub>CC</sub>	3	5	5.25	V	
Operating Temperature (package base)	T <sub>PKG BASE</sub>	-40		85	°C	
RF Frequency Range	F <sub>RF</sub>	1805	1850	1915	MHz	Typical application schematic with external matching components ( <b>note 1</b> ).
RF_IN Port Impedance	Z <sub>RFIN</sub>		50		Ω	Single-ended with 3-element match.
RF_OUT Port Impedance	Z <sub>RFOUT</sub>		50		Ω	Single-ended with 3-element match.

**Note 1:** Operation outside this range is possible, but with degraded performance of some parameters.

## Nominal Operating Parameters – General

The following conditions apply unless noted otherwise: typical application schematic using the 1805 to 1915 MHz tuning set.  $V_{CC} = 5\text{ V}$ ,  $V_{SHDN} = \text{LOW}$ ,  $I_{CCQ} = 365\text{ mA}$ ,  $P_{OUT} = 26\text{ dBm}$ ,  $F_{TEST} = 1850\text{ MHz}$ ,  $M5 = 7.68\text{ k}\Omega$ ,  $M9 = 5.62\text{ k}\Omega$ ,  $50\ \Omega$  system impedance,  $T_{PKG\ BASE} = 25\text{ }^\circ\text{C}$ . Evaluation board losses are included within the specifications.

Parameter	Symbol	Specification			Unit	Condition
		Min.	Typ.	Max.		
Supply Current (quiescent)	$I_{CCQ}$		365		mA	$I_{CCQ1} + I_{CCQ2}$ . No RF applied.
Supply Current with RF Applied	$I_{CC}$		625		mA	$I_{CC1} + I_{CC2}$ , RF applied with $P_{OUT} = 26\text{ dBm}$ .
Enable Current 1	$I_{ENABLE1}$		0.3		mA	$V_{CC} = 5\text{ V}$ .
Enable Current 2	$I_{ENABLE2}$		0.4		mA	$V_{CC} = 5\text{ V}$ .
Operating Temperature Range	$T_{PKG\ BASE}$	-40		+85	$^\circ\text{C}$	Measured on package base.
Logic Input Low	$V_{IL}$	0		0.8	V	Applies to $V_{SHDN}$ input.
Logic Input High	$V_{IH}$	1.8		$V_{CC}$	V	Applies to $V_{SHDN}$ Input.
Logic Current Low	$I_{IL}$		1.3		nA	Applies to $V_{SHDN}$ input, $V_{IL} = 0.8\text{ V}$ .
Logic Current High	$I_{IH}$		65		$\mu\text{A}$	Applies to $V_{SHDN}$ input, $V_{IH} = 1.8\text{ V}$ .
			285			Applies to $V_{SHDN}$ input, $V_{IH} = 3.3\text{ V}$ .
Switching Rise Time	$T_{RISE}$		50		ns	Applies to $V_{SHDN}$ input.
Switching Fall Time	$T_{FALL}$		50		ns	Applies to $V_{SHDN}$ input.

### Disabled Mode

Supply Quiescent Current	$I_{CCQ-SHDN}$		10		$\mu\text{A}$	$V_{CC} = 5\text{ V}$ , $V_{SHDN}/V_{EN1}/V_{EN2} = \text{HIGH}$ .
Enable Current 1	$I_{ENABLE1-SHDN}$		0.6		mA	$V_{CC} = 5\text{ V}$ , $V_{SHDN}/V_{EN1}/V_{EN2} = \text{HIGH}$ .
Enable Current 2	$I_{ENABLE2-SHDN}$		0.8		mA	$V_{CC} = 5\text{ V}$ , $V_{SHDN}/V_{EN1}/V_{EN2} = \text{HIGH}$ .

### Thermal Data (Stage 1 and Stage 2)

Stage 1: Thermal Resistance (Infrared Scan). DC only (no RF applied).	$\Theta_{JC}$		60		$^\circ\text{C}/\text{W}$	On standard evaluation board.
Stage 2: Thermal Resistance (Infrared Scan). DC only (no RF applied).	$\Theta_{JC}$		30		$^\circ\text{C}/\text{W}$	On standard evaluation board.
Thermal Data Stage 1 & 2: See plot of junction Temp vs. Output Power.	$T_J$		TBD		$^\circ\text{C}$	$V_{CC} = V_{EN1} = V_{EN2} = 5\text{ V}$ . On standard evaluation board ( <b>note 2</b> ).

**Note 2:** MTTF >  $10^6$  hours for  $T_{CHANNEL} \leq 190\text{ }^\circ\text{C}$ .

### Nominal Operating Parameters – RF: 5 V, 1800 to 1920 MHz

The following conditions apply unless noted otherwise: typical application schematic using the 1805 to 1915 MHz tuning set.  $V_{CC} = 5\text{ V}$ ,  $V_{SHDN} = \text{LOW}$ ,  $I_{CCQ} = 365\text{ mA}$ ,  $P_{OUT} = 26\text{ dBm}$ ,  $F_{TEST} = 1850\text{ MHz}$ ,  $M5 = 7.68\text{ k}\Omega$ ,  $M9 = 5.62\text{ k}\Omega$ ,  $50\ \Omega$  system impedance,  $T_{PKG\ BASE} = 25\text{ }^\circ\text{C}$ . Evaluation board losses are included within the specifications.

Parameter	Symbol	Specification			Unit	Condition
		Min.	Typ.	Max.		
Small Signal Gain	S21		25.1		dB	$V_{CC} = 5\text{ V}$ , $P_{IN} = -25\text{ dBm}$ , $F_{TEST} = 1880\text{ MHz}$ .
Standby Mode Gain	S21 <sub>STBY</sub>		-27		dB	Disabled Mode, $V_{SHDN}/V_{EN1}/V_{EN2} = \text{HIGH}$ , $P_{IN} = 0\text{ dBm}$ .
Input Return Loss	S11		< -5.5		dB	$F_{RF} = 1805\text{ to }1915\text{ MHz}$ .
Output Return Loss	S22		< -8		dB	$F_{RF} = 1805\text{ to }1915\text{ MHz}$ .
Reverse Isolation	S12		< -39		dB	$F_{RF} = 1805\text{ to }1915\text{ MHz}$ .
Noise Figure	NF		4.4		dB	On standard evaluation board.
Output 3rd Order Intercept Point	OIP3		48		dBm	25 dBm $P_{OUT}$ per tone at 600 kHz spacing.
Output 1 dB Compression Power	OP1dB		34.9		dBm	$V_{CC} = 5\text{ V}$ , sine wave input.
Adjacent Channel Leakage Ratio	ACLR		-46		dBc	$V_{CC} = 5\text{ V}$ , $P_{OUT} = 26\text{ dBm}$ , $F_{TEST} = 1880\text{ MHz}$ , LTE 20MHz 100RB TM1.1 Downlink Waveform with 9.6dB PAR.

**Note 3:** MIN/MAX limits defined using *modelled estimates* that account for part-to-part variations and expected process spreads. As additional production lots are fabricated, accumulated test data will be used to refine the MIN/MAX limits.

### GRF5618 Typical Operating Curves: 1805 to 1915 MHz Tune

GRF5618 Gain vs Frequency at Pin = -25 dBm

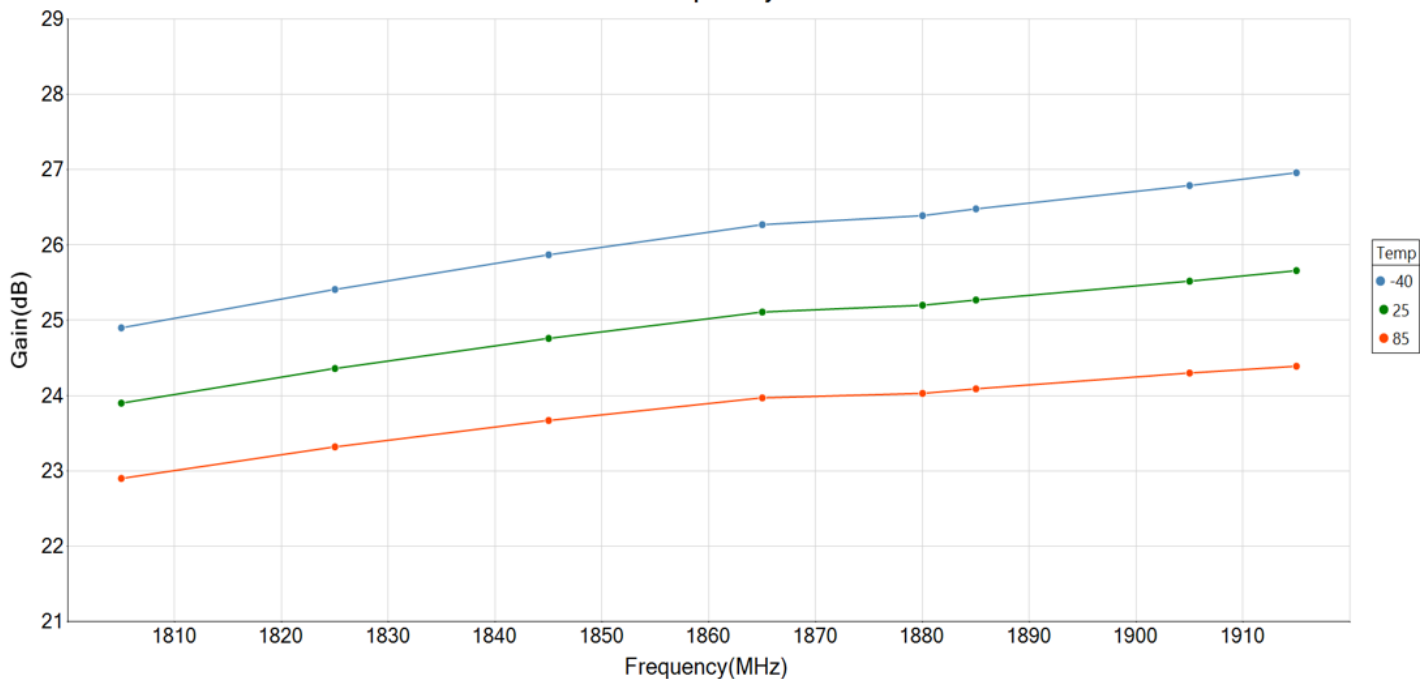

GRF5618 OP1dB vs Frequency

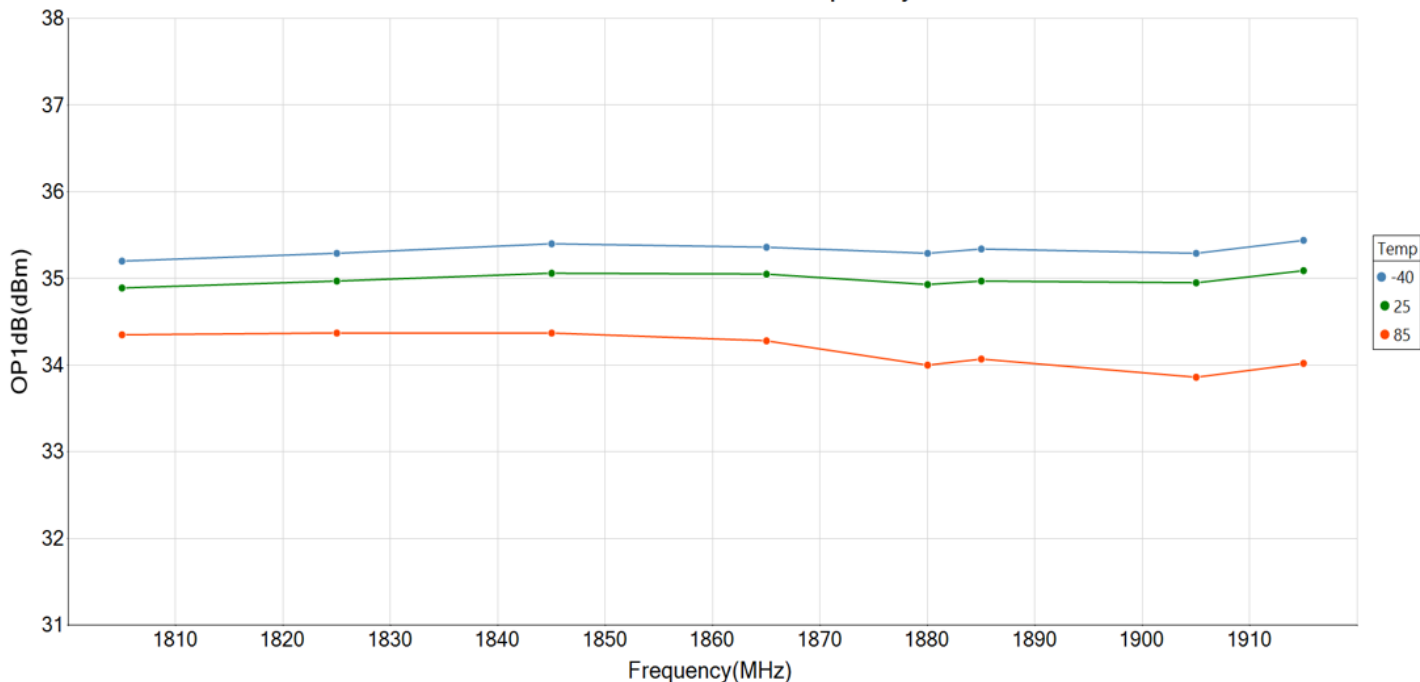

GRF5618 Typical Operating Curves: ACLR vs. Pout (LTE 20Q100RB TM1.1 9.6 dB PAR)

GRF5618 ACLR1 vs Pout at Modulation = LTE\_20MHz\_100RB and Frequency = 1880 MHz

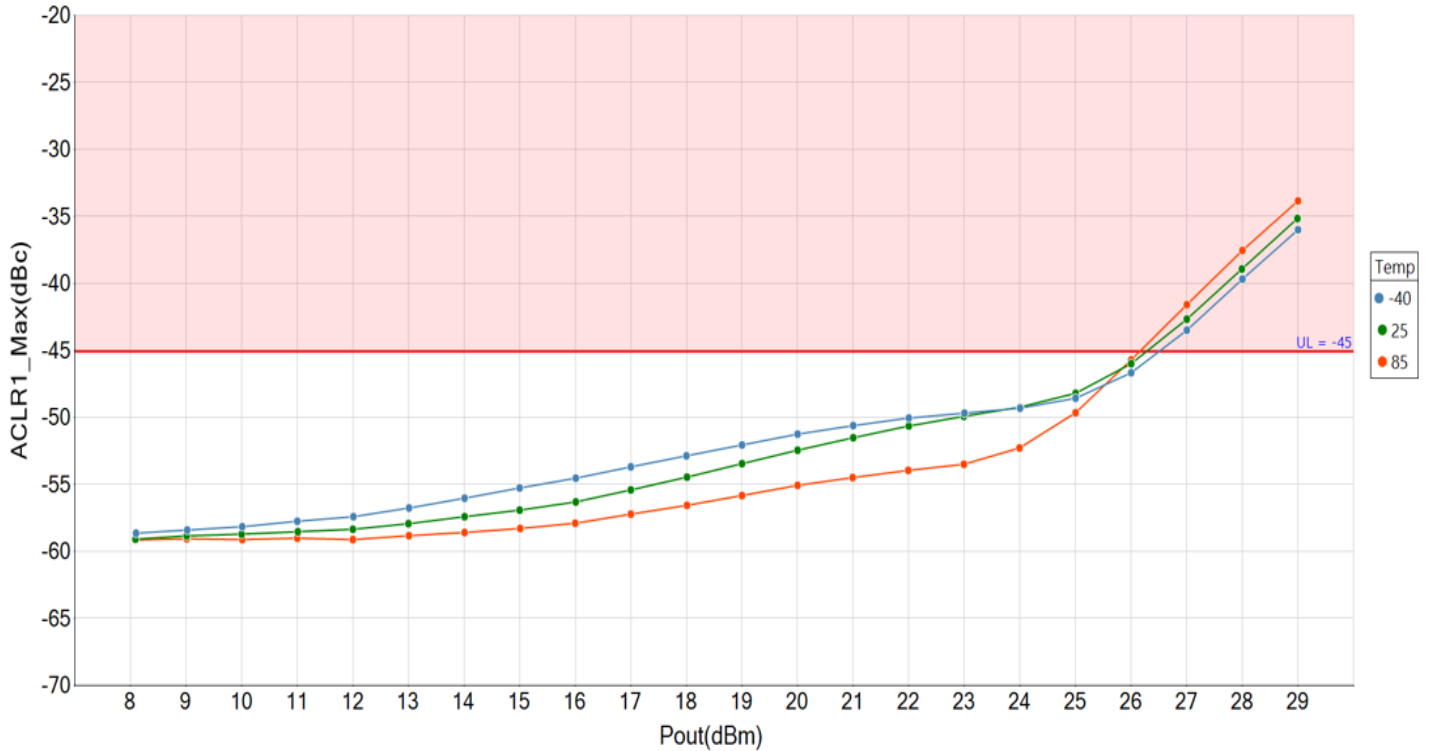

GRF5618 Typical Operating Curves: Stage 1 + Stage 2 Icc vs. Pout (LTE 20Q100RB TM1.1 9.6 dB PAR)

GRF5618 IccTot vs Pout at Modulation = LTE\_20MHz\_100RB and Frequency = 1880 MHz

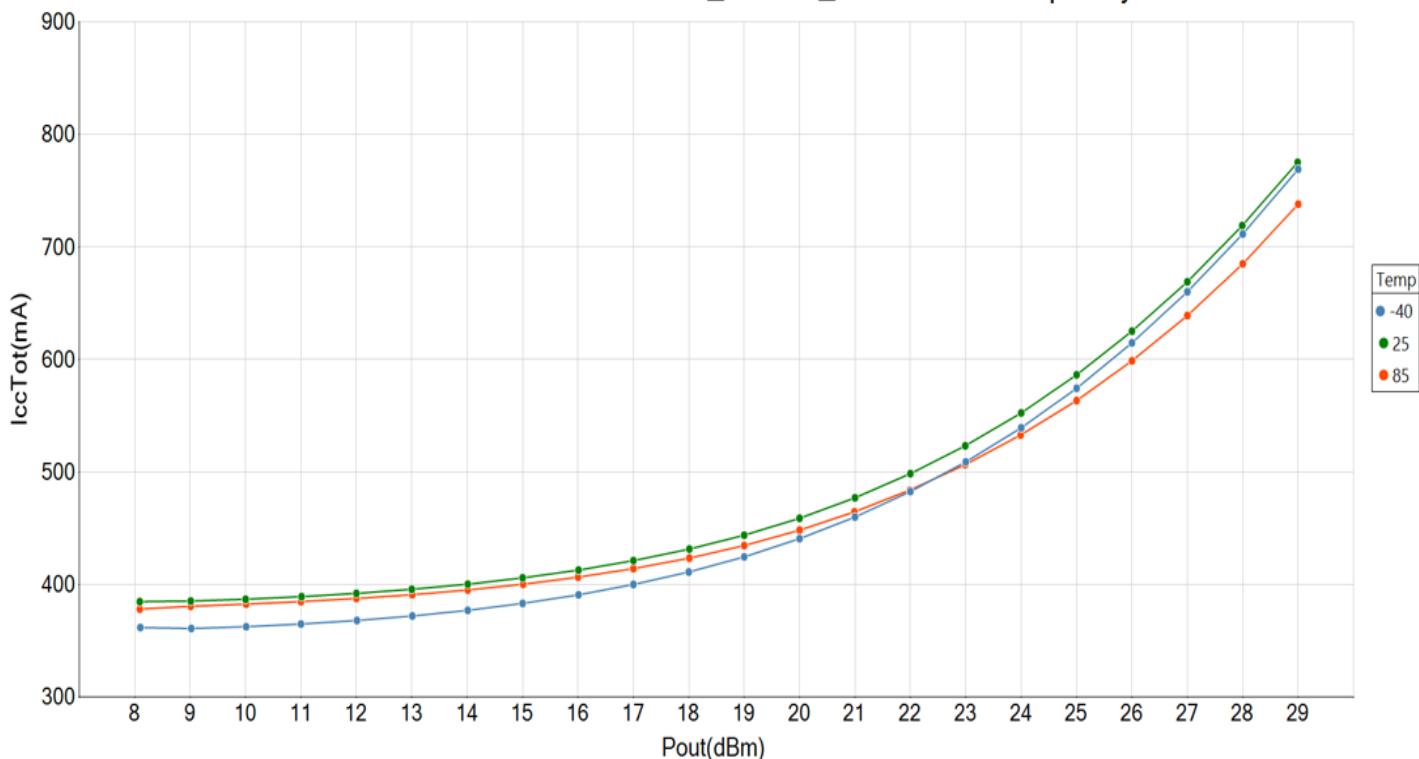

**GRF5618 Typical Operating Curves: EVM vs. Pout (LTE 20Q100RB TM1.1 9.6 dB PAR)**

GRF5618 EVM\_RMS vs Pout at Modulation = LTE\_20MHz\_100RB and Frequency = 1880 MHz

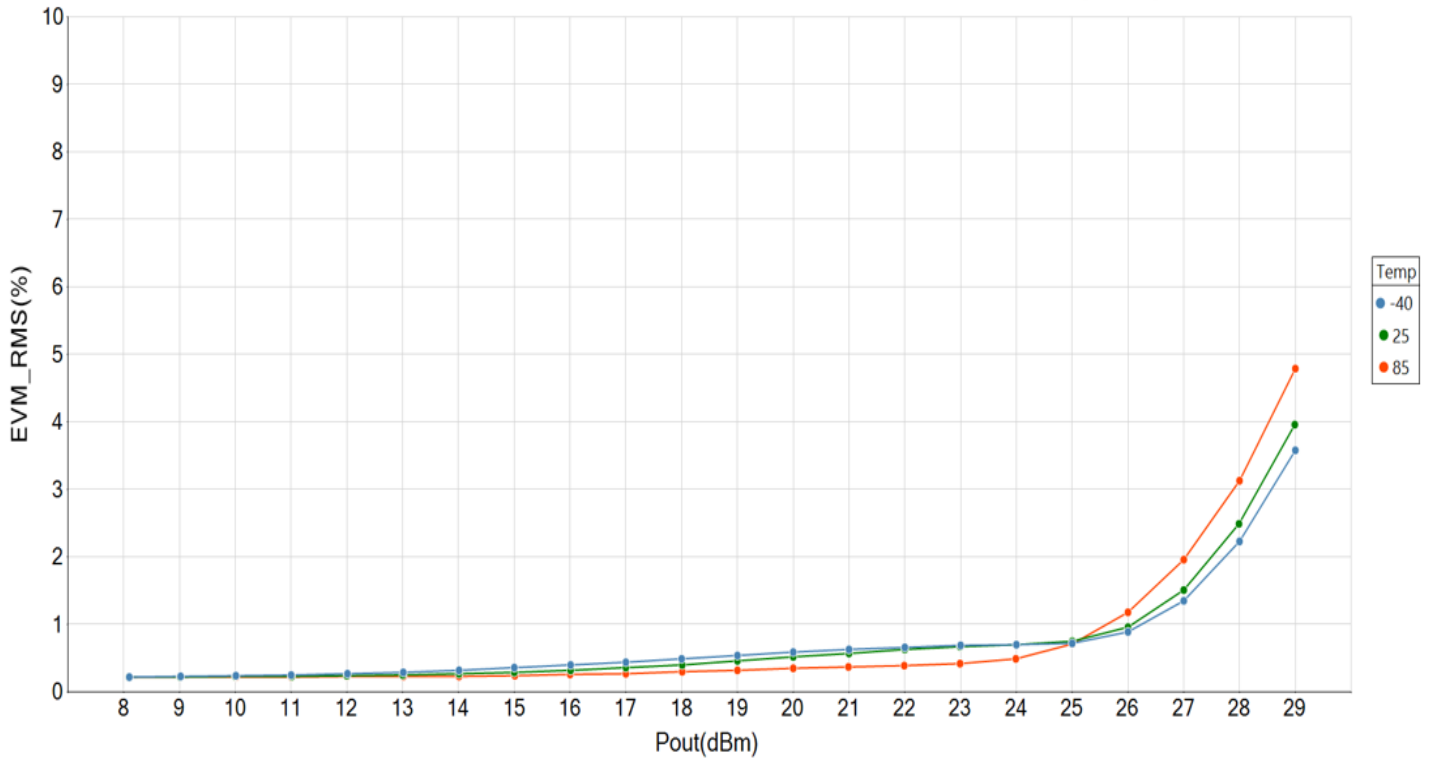

GRF5618 Typical Operating Curves: S-Parameters (1805 to 1915 MHz Tune)

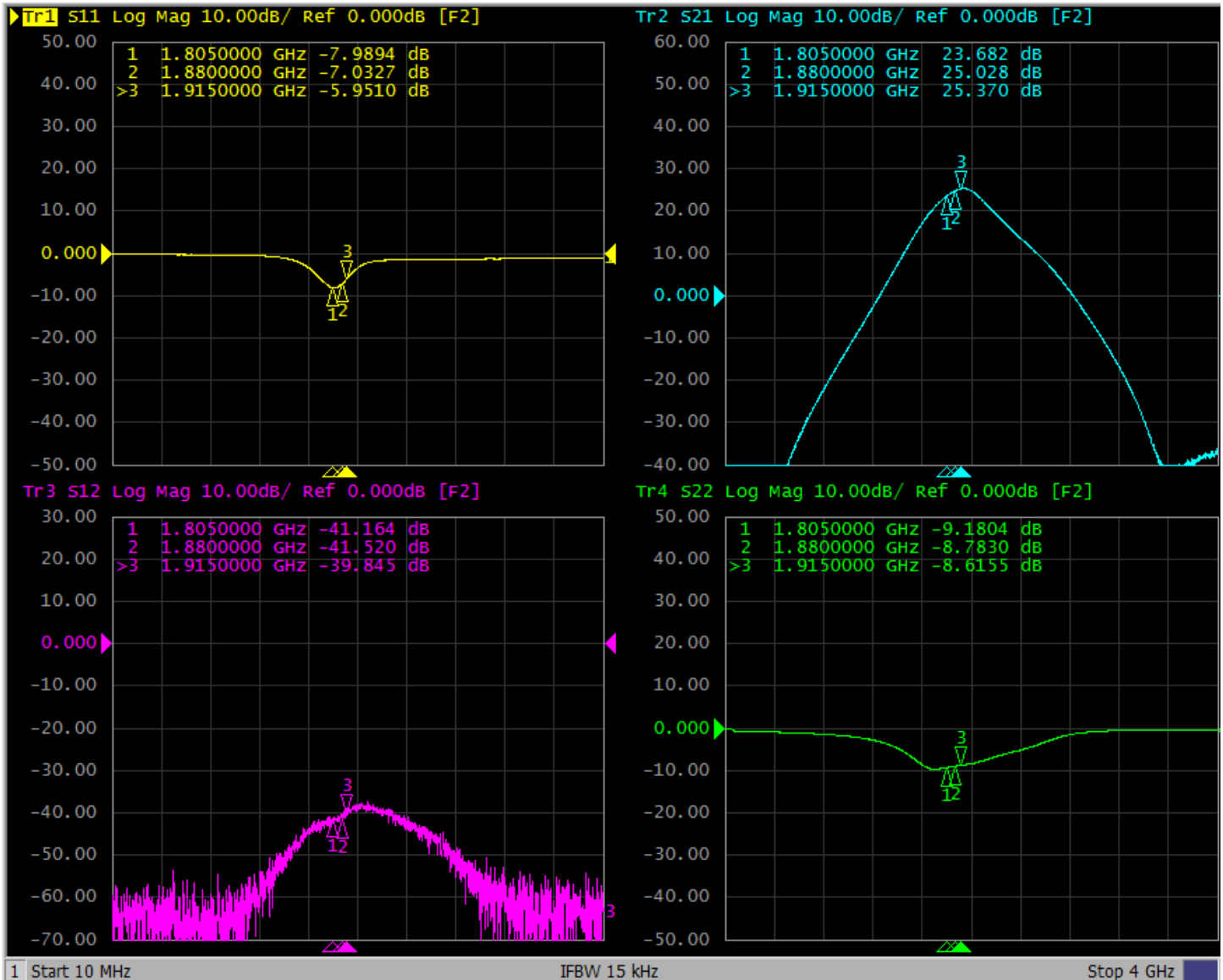

GRF5618 Typical Operating Curves: Stability Mu (10 MHz to 20 GHz)

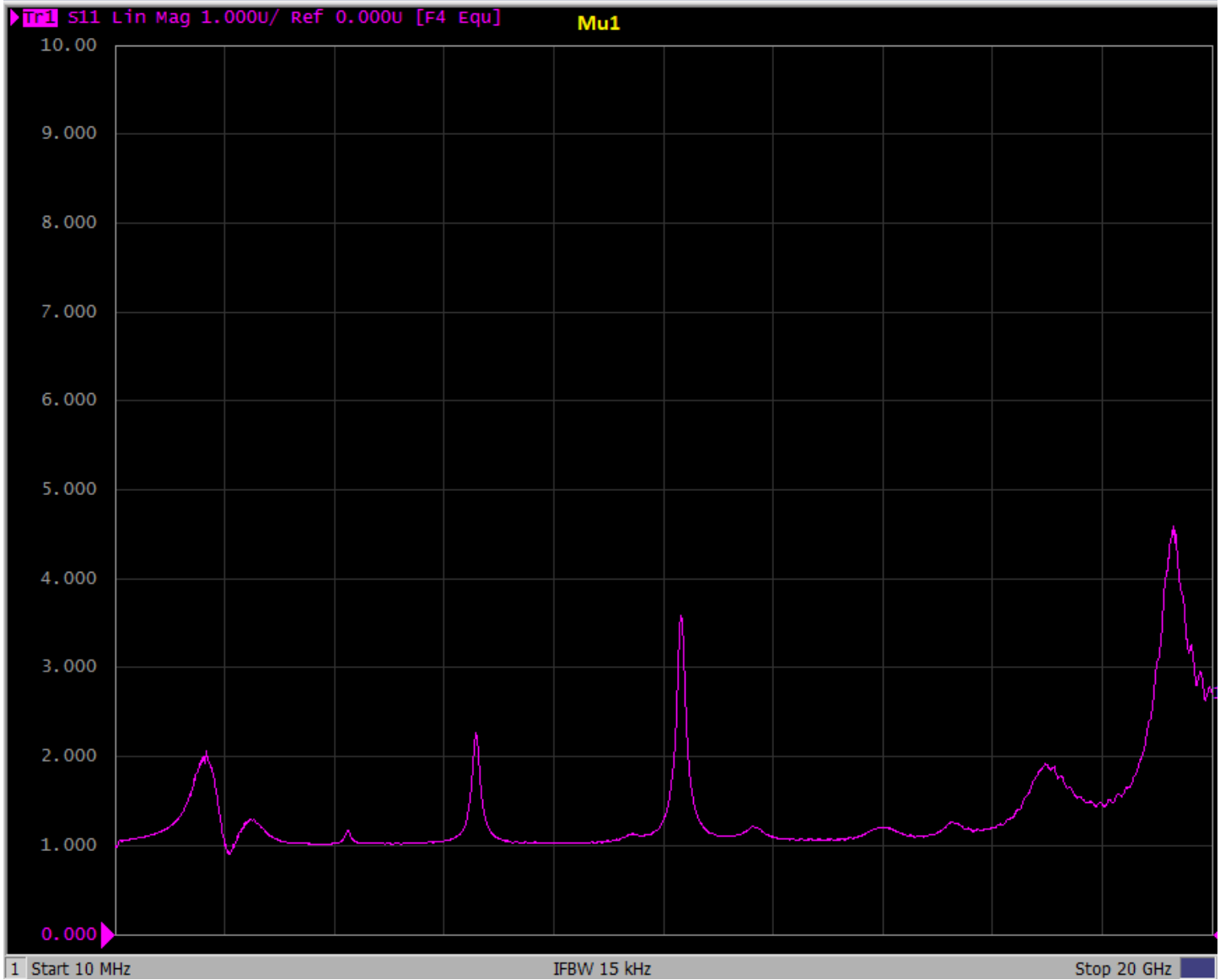

Note: Mu Factor  $\geq 1.0$  implies unconditional stability.

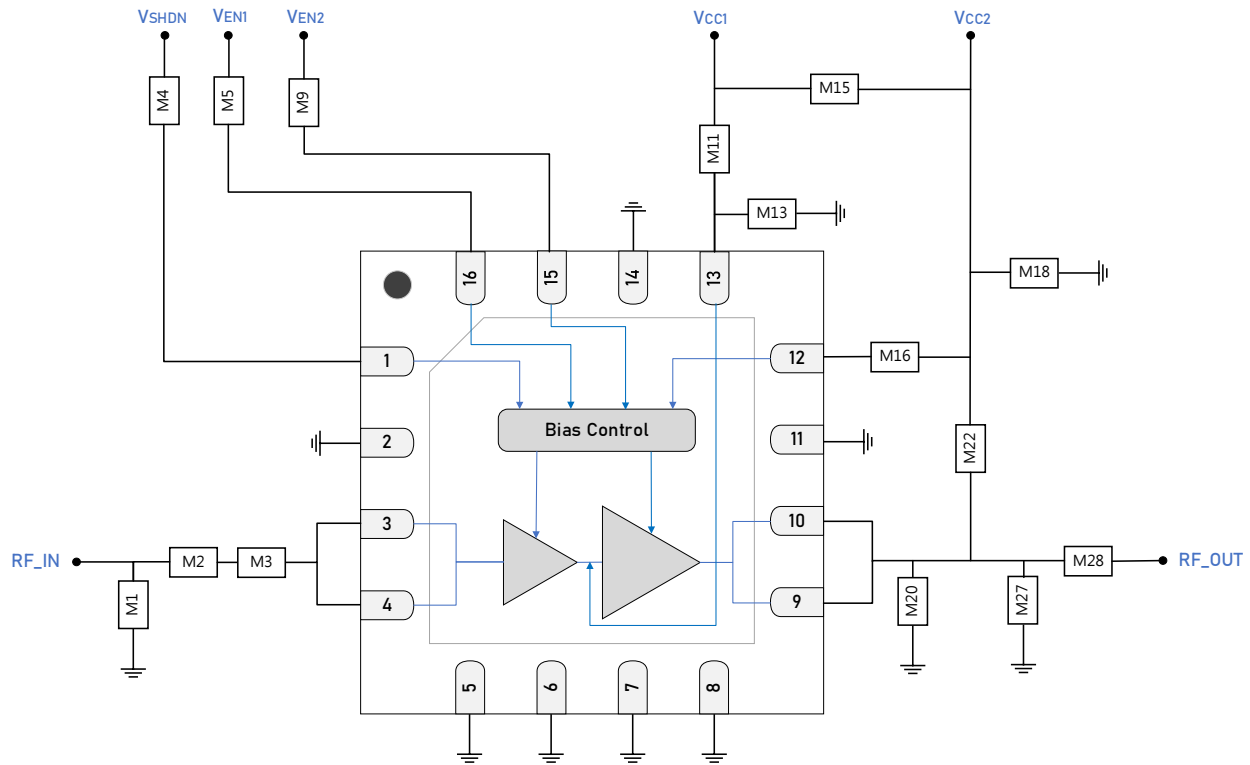

**GRF5618 Standard Evaluation Board Schematic**

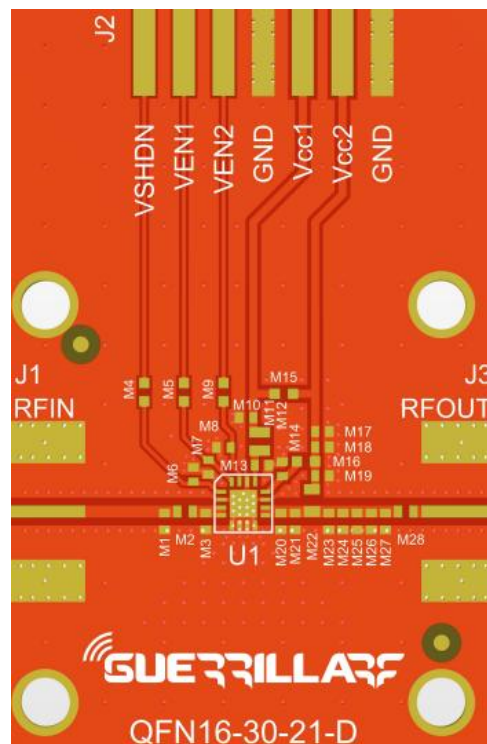

**GRF5618 Evaluation Board Assembly Diagram**

### GRF5618 Evaluation Board Assembly Diagram Reference

Component	Type	Manufacturer	Family	Value	Package Size	Substitution
M1	Inductor	Murata	LQG	1.8 nH	0402	ok
M2	Capacitor	Murata	GJM	2.2 pF	0402	ok
M3	Resistor	Various	--	1.5 Ω	0402	ok
M4	Resistor	Various	--	0 Ω	0402	ok
M5	Resistor	Various	1%	7680 Ω	0402	ok
M9	Resistor	Various	1%	5620 Ω	0402	ok
M11	Inductor	Coilcraft	0402HP	22 nH	0402	ok
M13	Capacitor	Murata	GRM	0.1 μF	0402	ok
M15	Resistor (jumper)	Various	--	0 Ω	0402	ok
M16	Resistor (jumper)	Various	--	0 Ω	0402	ok
M18	Capacitor	Murata	GRM	** 10 μF	0402	ok
M20	Capacitor	Murata	GJM	5.1 pF	0402	ok
M22	Inductor	Murata	LQW18AN 80	6.8 nH	0603	ok
M27	Capacitor	Murata	GJM	1.5 pF	0402	no
M28	Capacitor	Murata	GJM	22 pF	0402	ok
Evaluation Board	QFN16-30-21-D					

**Notes:**

 Standard evaluation board bias:  $V_{CC} = 5\text{ V}$ ,  $V_{ENABLE} = 5\text{ V}$ .

\*\* 10 μF must be rated for &gt; 5 V maximum ambient temperature. Manufacturer Part Number in this case = GRM155C80J106ME11D.

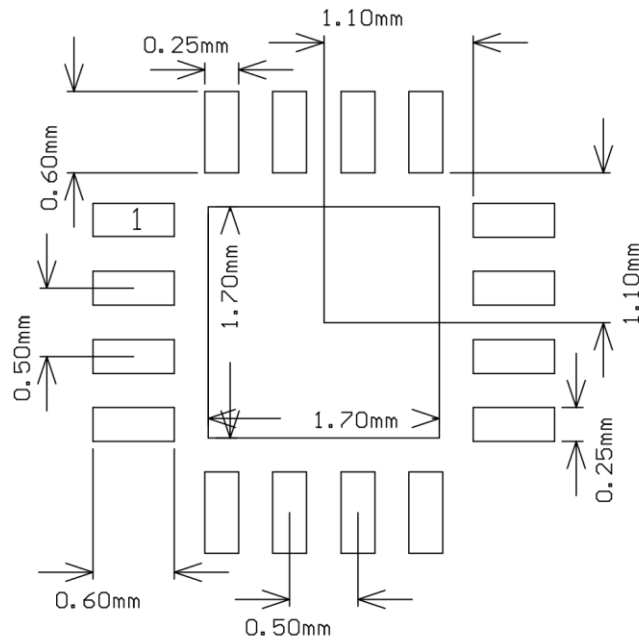

**3 x 3 mm QFN-16 Suggested PCB Footprint (Top View)**

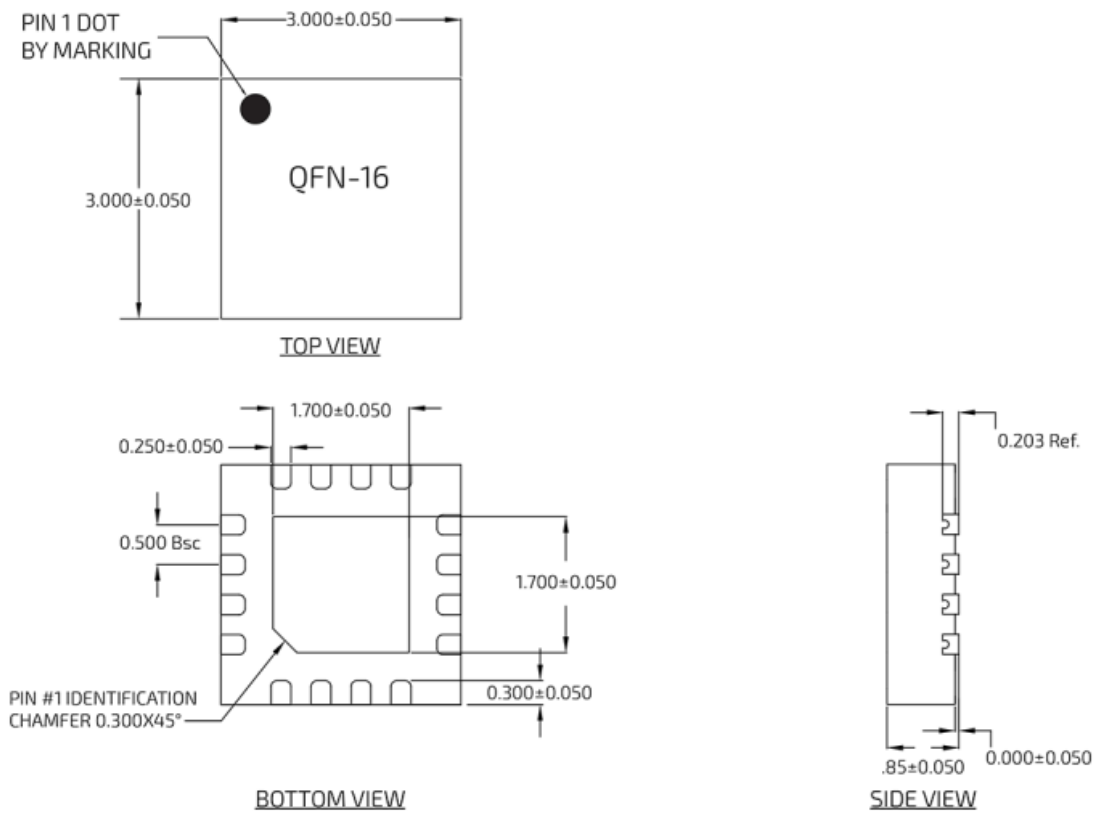

**3 x 3 mm QFN-16 Package Dimensions**

## Package Marking Diagram



- Line 1: "XXXX" = PART NUMBER.
- Line 2: "YY" = YEAR and "WW" = WEEK the device was assembled.

## Tape and Reel Information

Guerrilla RF's tape and reel specification complies with Electronic Industries Alliance (EIA) standards for "Embossed Carrier Tape of Surface Mount Components for Automatic Handling" (reference EIA-481). See the following page for the Tape and Reel Specification and Device Package Information table, which includes units per reel.

Devices are loaded with pins down into the carrier pocket with protective cover tape and reeled onto a plastic reel. Each reel is packaged in a cardboard box. There are product labels on the reel, the protective ESD bag and the outside surface of the box.

For the Tape and Reel Reference Table, please refer to: <https://www.guerrilla-rf.com/prodFiles/Manufacturing/MN001.pdf>

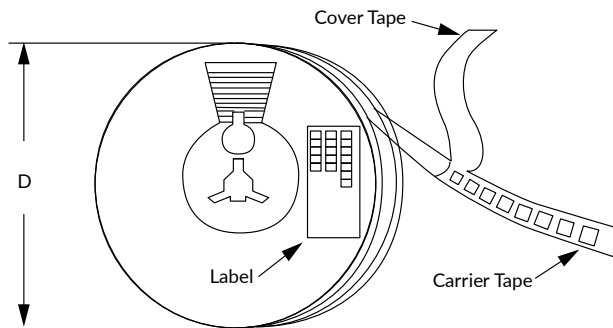

Tape and Reel Packaging with Reel Diameter Noted (D)

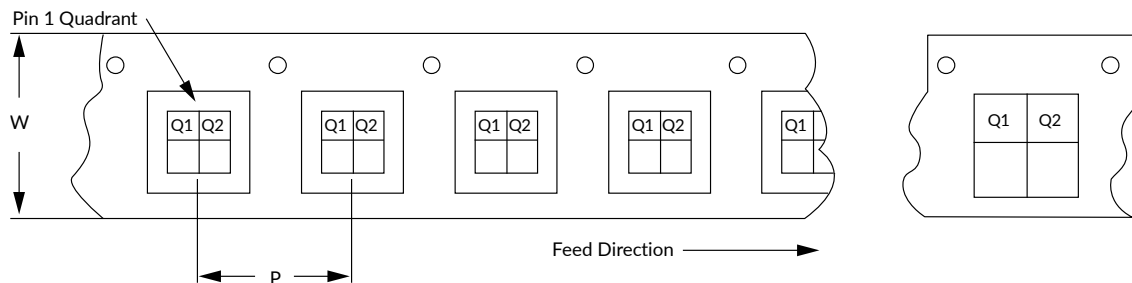

Carrier Tape Width (W), Pitch (P), Feed Direction and Pin 1 Quadrant Information



## Revision History

Revision Date	Description of Change
December 7, 2023	Preliminary Datasheet – initial release.
February 11, 2025	Upgraded Data Sheet with cosmetic changes only. No change to device or device specifications.
June 12, 2025	Page 1: updated lower frequency range for GRF5608 and GRF5610.
August 5, 2025	Release Ø Data Sheet. Updated plots on pages 8, 9, 10 and 11.



### Datasheet Classifications

Data Sheet Status	Notes
Advance	S-parameter and NF data based on EM simulations for the fully packaged device using foundry-supplied transistor S-parameters. Linearity estimates based on device size, bias condition and experience with related devices.
Preliminary	All data based on limited evaluation board measurements taken within the Guerrilla RF Applications Lab. All parametric values are subject to change pending the collection of additional data.
Release Ø	All data based on measurements taken with <i>production-released</i> material. TYP values are based on a combination of ATE and bench-level measurements, with MIN/MAX limits defined using <i>modelled estimates</i> that account for part-to-part variations and expected process spreads. Although unlikely, future refinements to the TYP/MIN/MAX values may be in order as multiple lots are processed through the factory.
Release A-Z	All data based on measurements taken with production-released material <i>derived from multiple lots which have been fabricated over an extended period of time</i> . MIN/MAX limits may be refined over previous releases as more statistically significant data is collected to account for process spreads.

Information in this datasheet is specific to the Guerrilla RF, Inc. ("Guerrilla RF") product identified.

This datasheet, including the information contained in it, is provided by Guerrilla RF as a service to its customers and may be used for informational purposes only by the customer. Guerrilla RF assumes no responsibility for errors or omissions on this datasheet or the information contained herein. Information provided is believed to be accurate and reliable, however, no responsibility is assumed by Guerrilla RF for its use, nor for any infringement of patents, or other rights of third parties, resulting from its use. Guerrilla RF assumes no liability for any datasheet, datasheet information, materials, products, product information, or other information provided hereunder, including the sale, distribution, reproduction or use of Guerrilla RF products, information or materials.

No license, whether express, implied, by estoppel, by implication or otherwise is granted by this datasheet for any intellectual property of Guerrilla RF, or any third party, including without limitation, patents, patent rights, copyrights, trademarks and trade secrets. All rights are reserved by Guerrilla RF.

All information herein, products, product information, datasheets, and datasheet information are subject to change and availability without notice. Guerrilla RF reserves the right to change component circuitry, recommended application circuitry and specifications at any time without prior notice. Guerrilla RF may further change its datasheet, product information, documentation, products, services, specifications or product descriptions at any time, without notice. Guerrilla RF makes no commitment to update any materials or information and shall have no responsibility whatsoever for conflicts, incompatibilities, or other difficulties arising from any future changes.

GUERRILLA RF INFORMATION, PRODUCTS, PRODUCT INFORMATION, DATASHEETS AND DATASHEET INFORMATION ARE PROVIDED "AS IS" AND WITHOUT WARRANTY OF ANY KIND, WHETHER EXPRESS, IMPLIED, STATUTORY, OR OTHERWISE, INCLUDING FITNESS FOR A PARTICULAR PURPOSE OR USE, MERCHANTABILITY, PERFORMANCE, QUALITY OR NON-INFRINGEMENT OF ANY INTELLECTUAL PROPERTY RIGHT; ALL SUCH WARRANTIES ARE HEREBY EXPRESSLY DISCLAIMED. GUERRILLA RF DOES NOT WARRANT THE ACCURACY OR COMPLETENESS OF THE INFORMATION, TEXT, GRAPHICS OR OTHER ITEMS CONTAINED WITHIN THESE MATERIALS. GUERRILLA RF SHALL NOT BE LIABLE FOR ANY DAMAGES, INCLUDING BUT NOT LIMITED TO ANY SPECIAL, INDIRECT, INCIDENTAL, STATUTORY, OR CONSEQUENTIAL DAMAGES, INCLUDING WITHOUT LIMITATION, LOST REVENUES OR LOST PROFITS THAT MAY RESULT FROM THE USE OF THE MATERIALS OR INFORMATION, WHETHER OR NOT THE RECIPIENT OF MATERIALS HAS BEEN ADVISED OF THE POSSIBILITY OF SUCH DAMAGE.

Customers are solely responsible for their use of Guerrilla RF products in the Customer's products and applications or in ways which deviate from Guerrilla RF's published specifications, either intentionally or as a result of design defects, errors, or operation of products outside of published parameters or design specifications. Customers should include design and operating safeguards to minimize these and other risks. Guerrilla RF assumes no liability or responsibility for applications assistance, customer product design, or damage to any equipment resulting from the use of Guerrilla RF products outside of stated published specifications or parameters.