

GRF0005

GaN HEMT Power Transistor 5 Watt P3dB DC to 12 GHz

FEATURES

- Operating Frequency Range: DC to 12 GHz
- Operating Drain Voltage: 28 and 40 Volt
- Maximum Output Power: 5 Watt (P3dB)
- Suitable for Pulsed, Linear Applications
- 100% DC & RF Production Tested
- Compact 3 x 3 mm QFN-16 Package

Reference: 40 V / 20 mA / 3 GHz

- Saturated Gain: 18.9 dB
- Saturated Drain Efficiency: 48.7 %
- Saturated Output Power: 38.7 dBm

APPLICATIONS

- Cellular Infrastructure
- Radar
- Communications
- Test Instrumentation

DESCRIPTION

The GRF0005 is a 5 W (P3dB) unmatched discrete GaN-on-SiC HEMT which operates from DC to 12 GHz on a 40 V supply rail. The wide bandwidth makes the GRF0005 suitable for a variety of applications including cellular infrastructure, radar, communications, and test instrumentation, and can support both linear and pulse operations. The device is housed in an industry-standard 3 x 3 mm surface mount QFN-16 package. Lead free and RoHS compliant.

Please consult with the GRF applications engineering team for custom tuning/evaluation board data.

BLOCK DIAGRAM

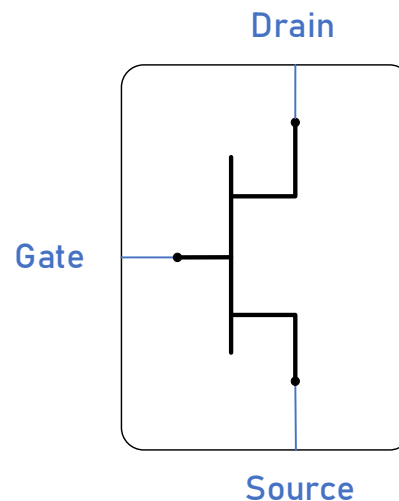

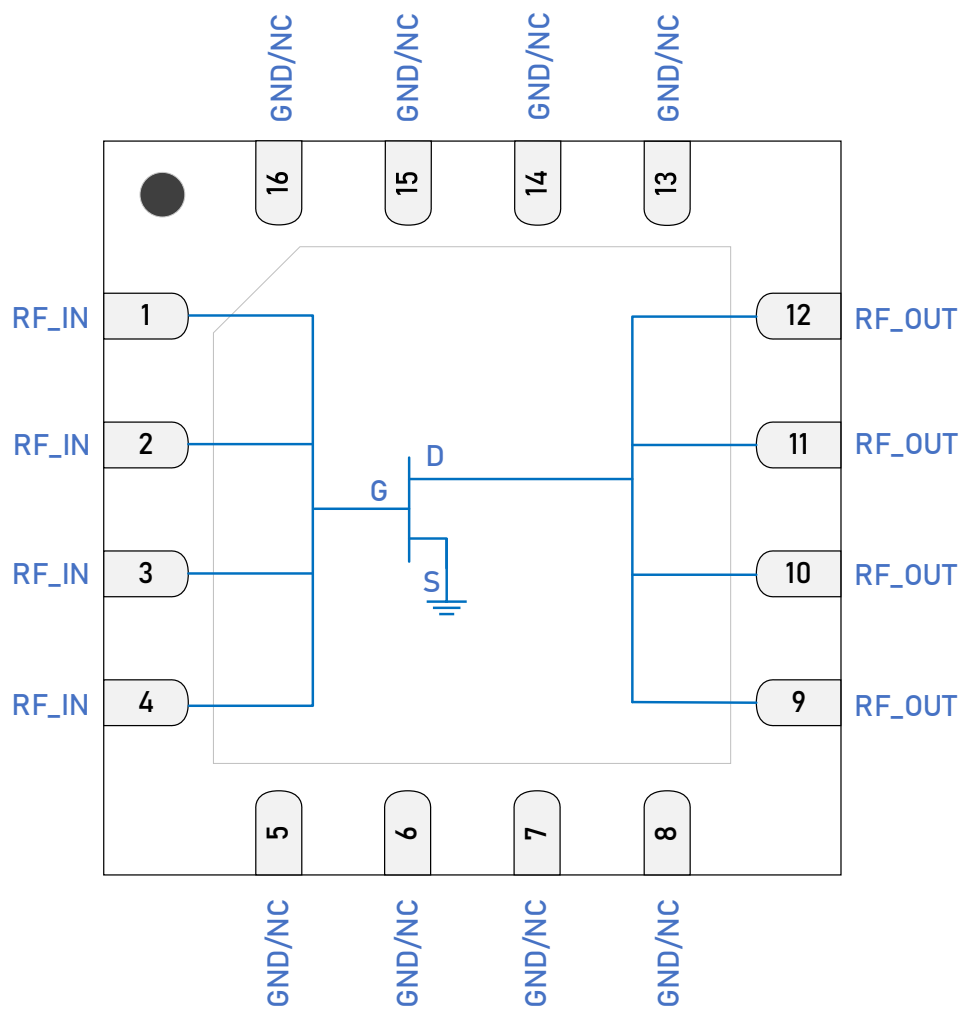

QFN-16 3 x 3 mm Pin Out (Top View)

Pin Assignments

Pin	Name	Description	Note
1, 2, 3, 4	RF_IN	Gate Voltage	Connected to GATE terminal of GaN transistor.
5, 6, 7, 8, 13, 14, 15, 16	GND/NC	Ground or No Connect	No internal connection to die. It is strongly recommended that these pins be connected to ground.
9, 10, 11, 12	RF_OUT	Drain Voltage	Connected to DRAIN terminal of GaN transistor.
PKG BASE	SOURCE	Source Connection	Connected to the SOURCE terminals of the GaN transistor. Provides DC and RF ground as well as thermal heat sink. In order to match the device's rated performance, it is strongly recommended to use multiple thermal vias beneath the package for optimal RF and thermal performance. Refer to evaluation board top layer graphic on schematic page.

GaN HEMT Power-up / Power-down Procedure:

To turn the transistor ON:

1. Set V_{GS} to -5 V.
2. Turn on V_{DS} to normal operation voltage (40 V).
3. Slowly increase V_{GS} to set I_{DQ} current to 20 mA.
4. Apply RF power.

To turn the transistor OFF:

1. Turn the RF power off.
2. Decrease V_{GS} to -5 V.
3. Turn off V_{DS} . Wait a few seconds for Drain capacitor to discharge.
4. Turn off V_{GS} .

Absolute Ratings

Parameter	Symbol	Min.	Max.	Unit
Operating Voltage	V_{DS}		50	V
Drain to Gate Breakdown Voltage	B_{VDG}		TBD	V
Drain to Source Voltage	V_{DS}		150	V
Gate to Source Voltage	V_{GS}	-8	2	V
Drain Current	I_D		550	mA
RF Input Power: 50 Ω , $V_{DS} = 40$ V, $I_{DQ} = 20$ mA, $T_{PKG\ BASE} = 85$ °C.	$P_{IN\ MAX}$		TBD	dBm
RF Input Power: 10:1 VSWR, $V_{DS} = 40$ V, $I_{DQ} = 20$ mA, $T_{PKG\ BASE} = 85$ °C.	$P_{IN\ MAX}$		TBD	dBm
Output Mismatch Stress: $V_{DS} = 40$ V, $P_{OUT} = P_{SAT}$ pulsed = TBD.	$VSWR_{MAX}$		TBD	
Operating Temperature (package base).	$T_{PKG\ BASE}$	-40	105	°C
Maximum Junction Temperature (MTTF > 10 ⁶ hours).	$T_{J\ MAX}$		225	°C
Maximum Dissipated Power	$P_{DISS\ MAX}$		TBD	W

Electrostatic Discharge

Human Body Model	HBM	TBD		V
Charged Device Model	CDM	TBD		V

Storage

Storage Temperature	T_{STG}	-65	150	°C
Moisture Sensitivity Level	MSL		1	--

Note 1: Exceeding any of these limits may cause permanent damage to the device or reduce the lifetime (MTTF).

Note 2: Guerrilla-RF does not recommend sustained operation above the maximum operating conditions.



Caution! ESD Sensitive Device.

Exceeding Absolute Maximum Rating conditions may cause permanent damage.

Note: For additional information, please refer to *Manufacturing Note MN-001 — Package and Manufacturing Information*.



All Guerrilla RF products are provided in RoHS compliant lead (Pb)-free packaging requiring no exemptions. Additional information for this topic can be found at this link - *Environmental and Restricted Substance Statement Library*

Recommended Operating Conditions

Parameter	Symbol	Specification			Unit	Condition
		Min.	Typ.	Max.		
RF Frequency Range	F_{TEST}	DC	3	12	GHz	Typical application schematic (notes 3 & 4).
Drain to Source Voltage	V_{DS}	28	40	50	V	Typical application schematic.
Drain Current (Quiescent)	I_{DQ}		20		mA	Typical application schematic.
Drain Current: RF	$I_{D-Drive}$	306			mA	Typical application schematic.
Gate Voltage	V_{GS}		-2.45		V	Typical application schematic.
Gate Current: RF	$I_{G-Drive}$		1		uA	Typical application schematic, $P_{OUT} = 5$ W.
Operating Temperature	$T_{PKG\ BASE}$	-40		85	°C	On package base.
Gate Port Impedance	Z_{RF_IN}		50		Ω	Typical application schematic.
Drain Port Impedance	Z_{RF_OUT}		50		Ω	Typical application schematic.

Note 3: Operation outside of this range is possible, but with degraded performance of some parameters.

Note 4: Contact the Guerrilla RF applications team for guidance on optimizing the tuning of the device for alternative bands.

Nominal Operating Parameters – General

The following conditions apply unless noted otherwise: typical application schematic using the 2.7 to 3.2 GHz tuning set, $V_{DS} = 40$ V, $I_{DQ} = 20$ mA, $P_{OUT} = 5$ W, $F_{TEST} = 3$ GHz, Pulsed CW (100 μ s pulse width, 10% duty cycle, no modulation), 50 Ω system impedance, $T_{AMB} = 25$ °C, $T_{PKG\ BASE} = -40$ to 85 °C. Evaluation board losses are included within the specifications.

Parameter	Symbol	Specification			Unit	Condition
		Min.	Typ.	Max.		
Drain Source Breakdown Voltage	B_{VDS}	50			V	
Drain Source Leakage Current	I_{DLK}		10		μ A	$V_{GS} = -8$ V, $V_{DS} = 40$ V.
Drain Current: Quiescent	I_{DQ}		20		mA	No RF applied.
Gate Threshold Voltage	V_{GS}	-3.4		-1.5	V	$V_{DS} = 40$ V.
Gate Bias Voltage	V_{GS}		-2.45		V	
Drain Voltage	V_{DS}		40		V	
Drain Current: RF	$I_{D-DRIVE}$		306		mA	RF applied, $P_{OUT} = 5$ W.
Gate Current: RF	$I_{G-DRIVE}$		1		μ A	RF applied, $P_{OUT} = 5$ W.
Gate Leakage Current	I_{G-LEAK}		1		μ A	

Thermal And Reliability Information: CW, $T_{CHANNEL} = 85$ °C

Thermal Resistance (Infrared Scan)	θ_{JC}		TBD		°C/W	$P_{OUT} = TBD$. On standard evaluation board.
Channel Temperature	$T_{CHANNEL}$		TBD		°C	

Note 5: MIN/MAX limits defined using modelled estimates that account for part-to-part variations and expected process spreads. As additional production lots are fabricated, accumulated test data will be used to refine the MIN/MAX limits.



Nominal Operating Parameters – RF: DC to 12 GHz

The following conditions apply unless noted otherwise: typical application schematic using the 2.7 to 3.2 GHz tuning set, $V_{DS} = 40\text{ V}$, $I_{DQ} = 20\text{ mA}$, $P_{OUT} = 5\text{ W}$, $F_{TEST} = 3\text{ GHz}$, Pulsed CW (100 μs pulse width, 10% duty cycle, no modulation), 50 Ω system impedance, $T_{AMB} = 25\text{ }^\circ\text{C}$, $T_{PKG\text{ BASE}} = -40\text{ to }85\text{ }^\circ\text{C}$. Evaluation board losses are included within the specifications.

Parameter	Symbol	Specification			Unit	Condition
		Min.	Typ.	Max.		
Small Signal Gain	G_{SS}		17		dB	At $I_{DS} \leq 1.1 * I_{DQ}$.
Power Gain	G_{MAX}		21.6		dB	Max gain vs. power.
Saturated Gain	G_{SAT}		18.9		dB	At 2.5 dB compression referenced to G_{MAX} .
Saturated Drain Efficiency	$D_{EFF(SAT)}$		48.7		%	
Saturated Output Power	P_{SAT}		38.7		dBm	
Ruggedness	Ψ	At 2.5 dB compression. Output VSWR = 10:1 (all angles)				No damage or shift in performance.

Note 6: MIN/MAX limits defined using *modelled estimates* that account for part-to-part variations and expected process spreads. As additional production lots are fabricated, accumulated test data will be used to refine the MIN/MAX limits.

Typical Performance:

Single-Tone Pulse CW (10% duty cycle, 100 μ s pulse width). 2nd Harmonic not optimized.

1. Optimum Peak Power at 2.5 dB compression.
2. Optimum Peak Efficiency at 2.5 dB compression.

$V_{DS} = 40$ V, $I_{DS} = 20$ mA, $T_{AMB} = 25$ °C

Frequency (MHz)	$P_{OUT}^{(1)}$ (dBm)	$P_{OUT}^{(1)}$ (W)	Gain ⁽²⁾ (dB)	Drain Eff ⁽²⁾ (%)
9000	38	6.5	10	52
9100	38	6.5	10	51
9200	37	5	10	50
9300	37	5	10	50
9400	37	5	10	50
9500	37	5	10	50

Typical Operating Curves: Single-Tone, $V_{DS} = 40\text{ V}$, $I_{DQ} = 12\text{ mA}$

Maximum Available Gain

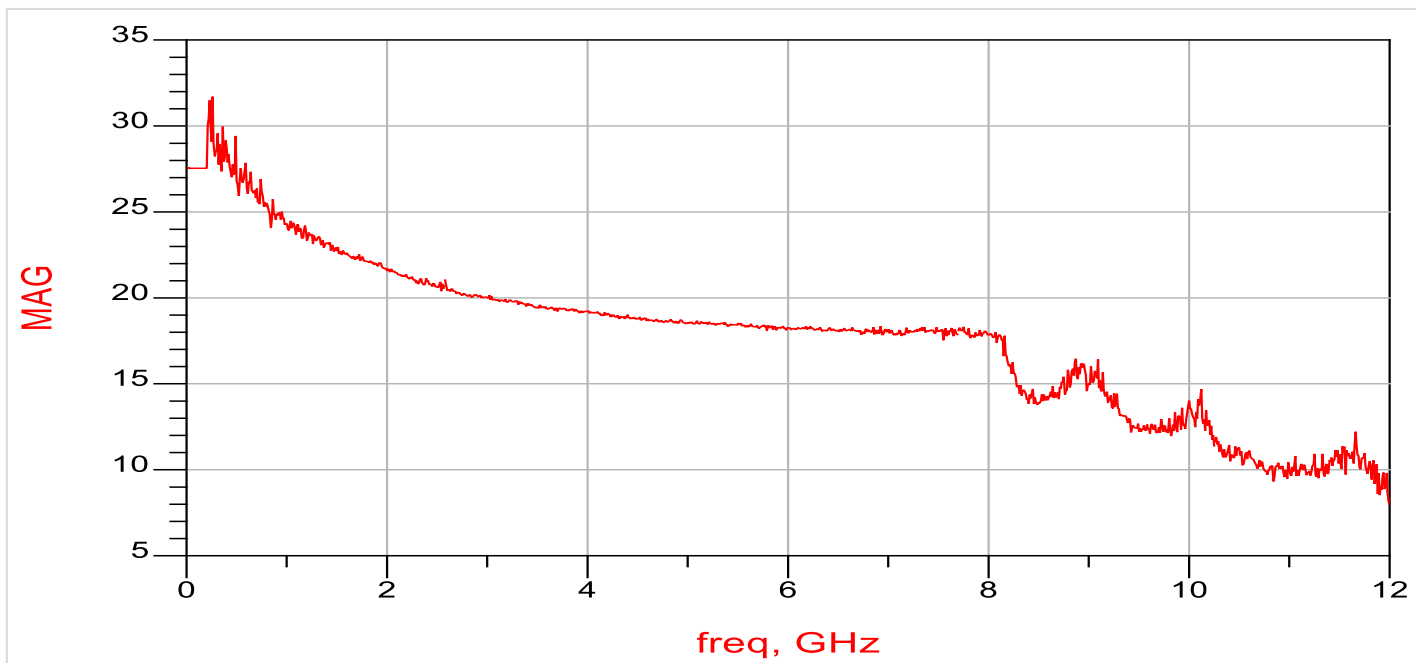

K-Factor

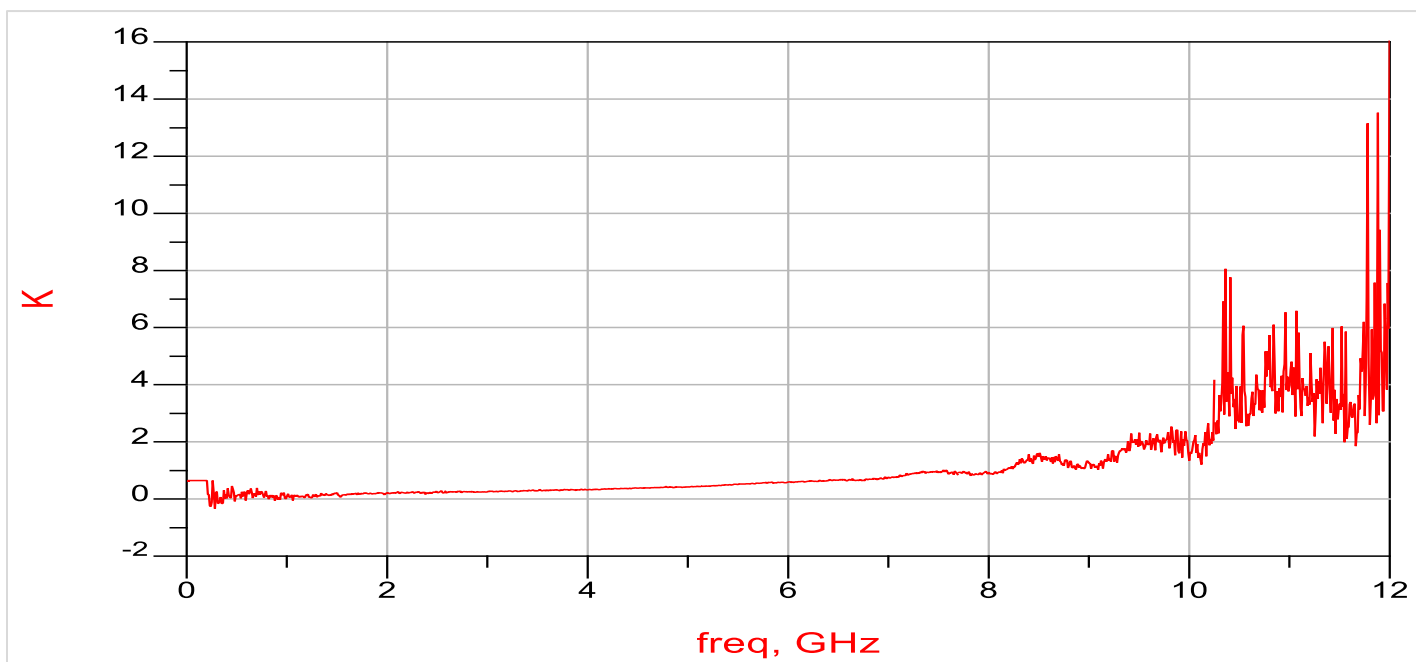

Typical Operating Curves: Single-Tone, $V_{DS} = 40\text{ V}$, $I_{DQ} = 12\text{ mA}$

Broadband S-Parameters (Mag-dB)

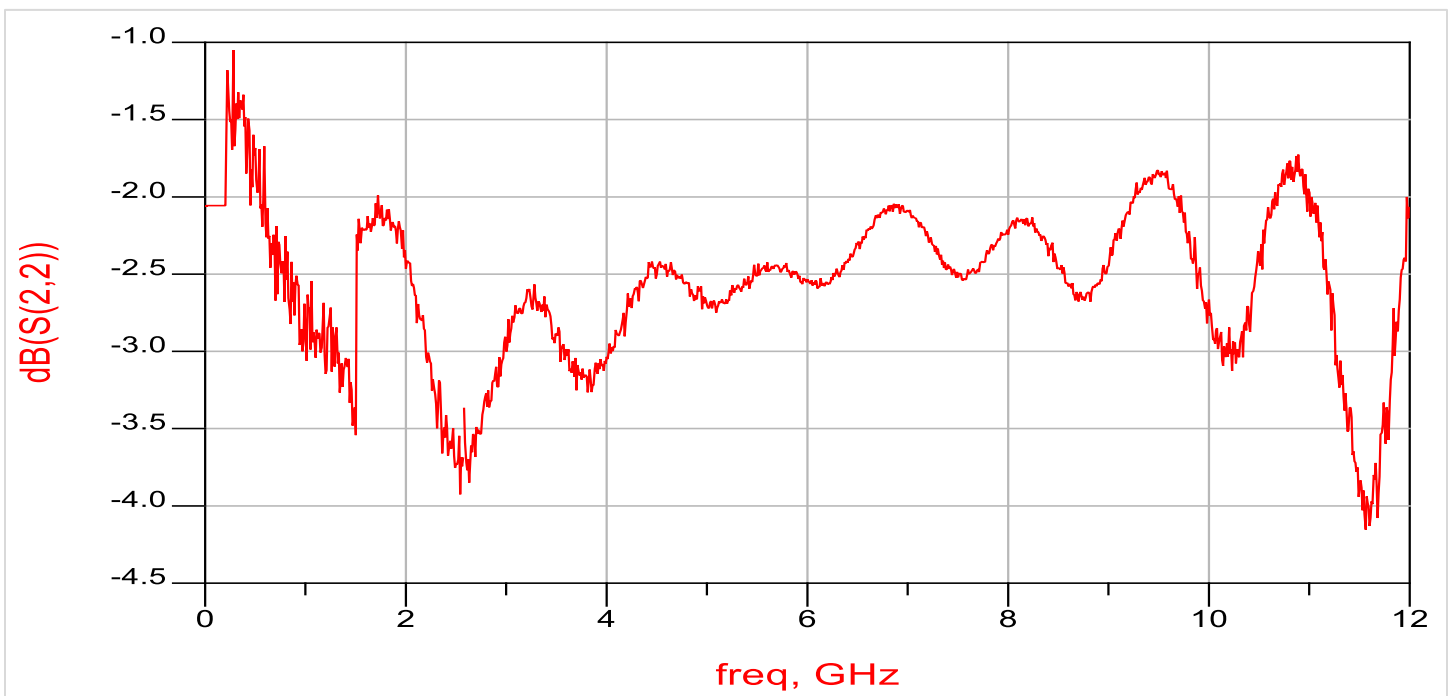
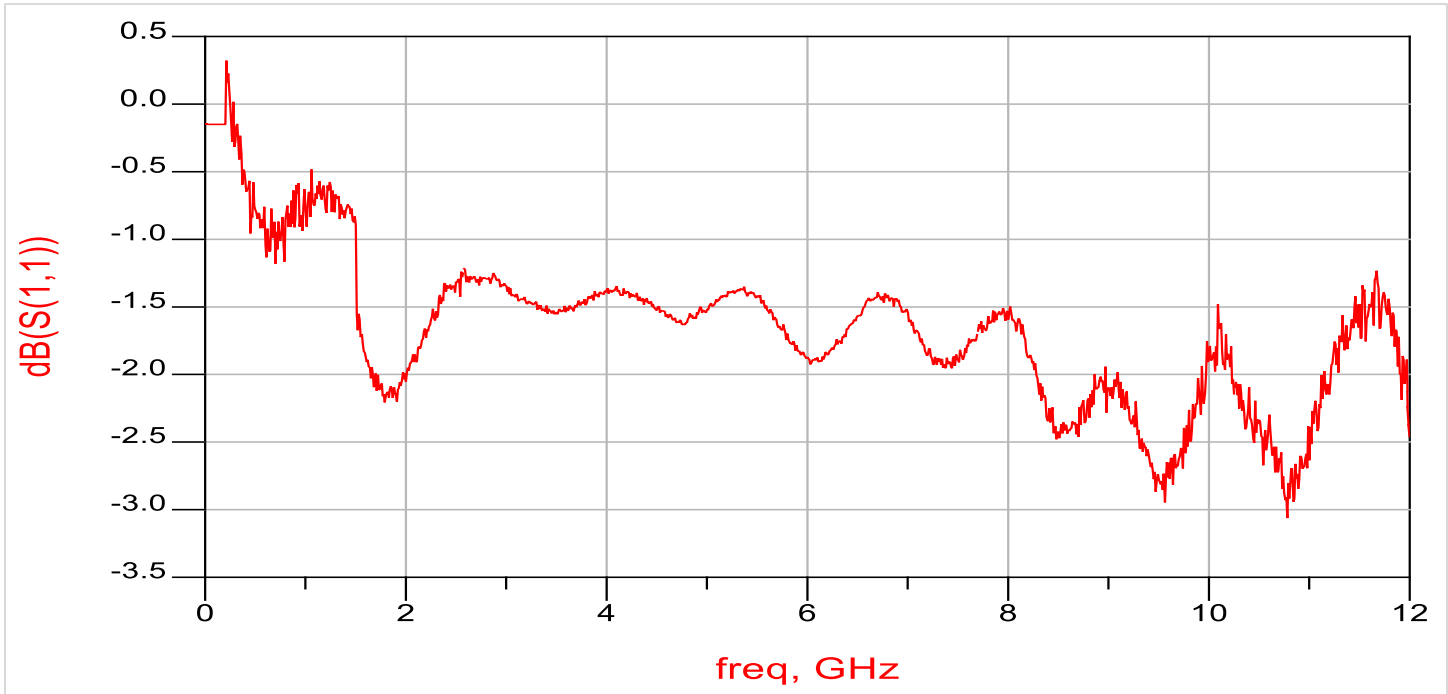

Typical Operating Curves: Single-Tone, $V_{DS} = 40\text{ V}$, $I_{DQ} = 12\text{ mA}$

Broadband S-Parameters (Mag-dB)

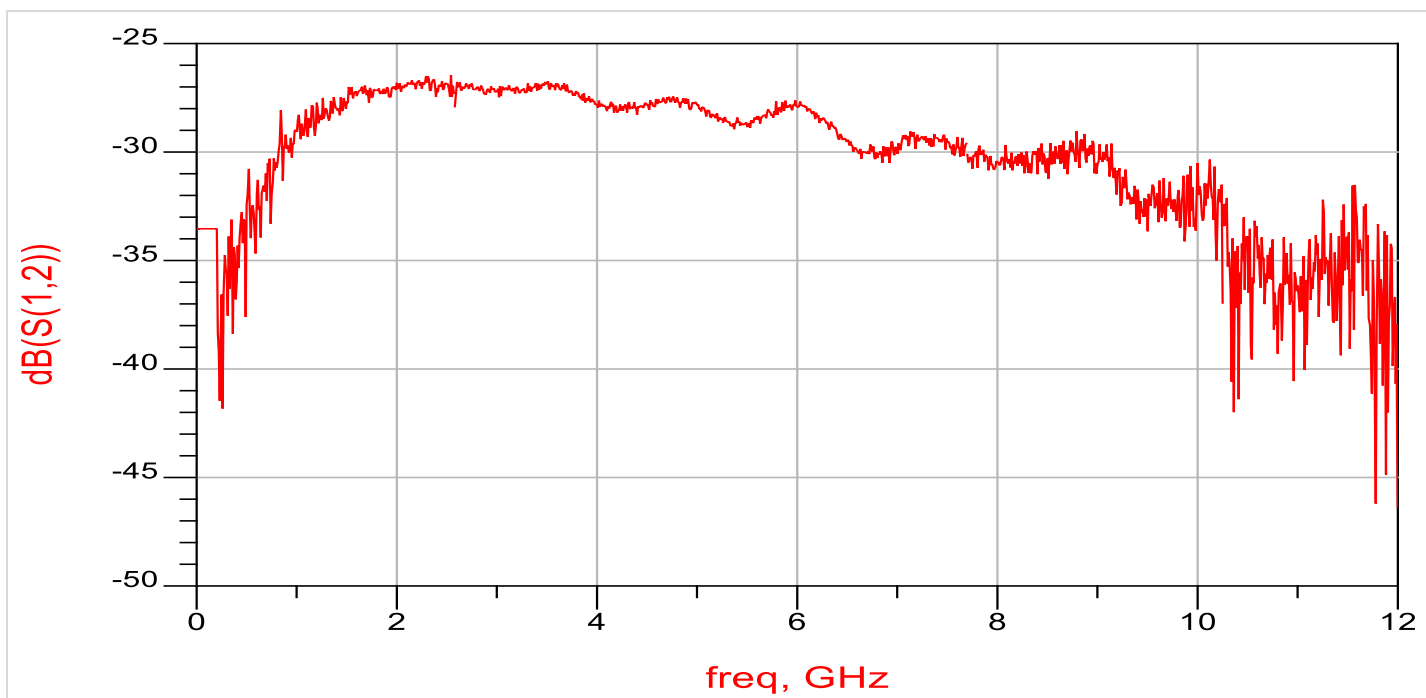
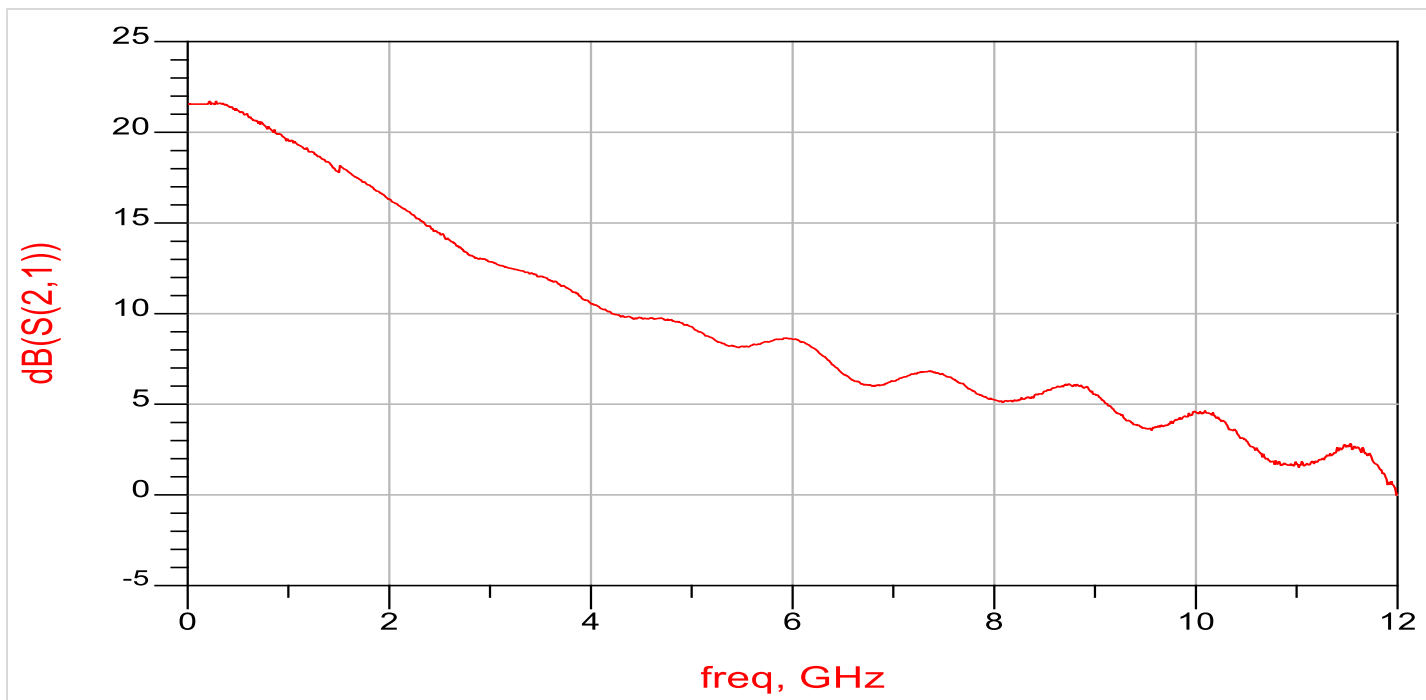

Typical Operating Curves: Single-Tone, $V_{DS} = 40\text{ V}$, $I_{DQ} = 12\text{ mA}$

Broadband S-Parameters (Mag-dB)

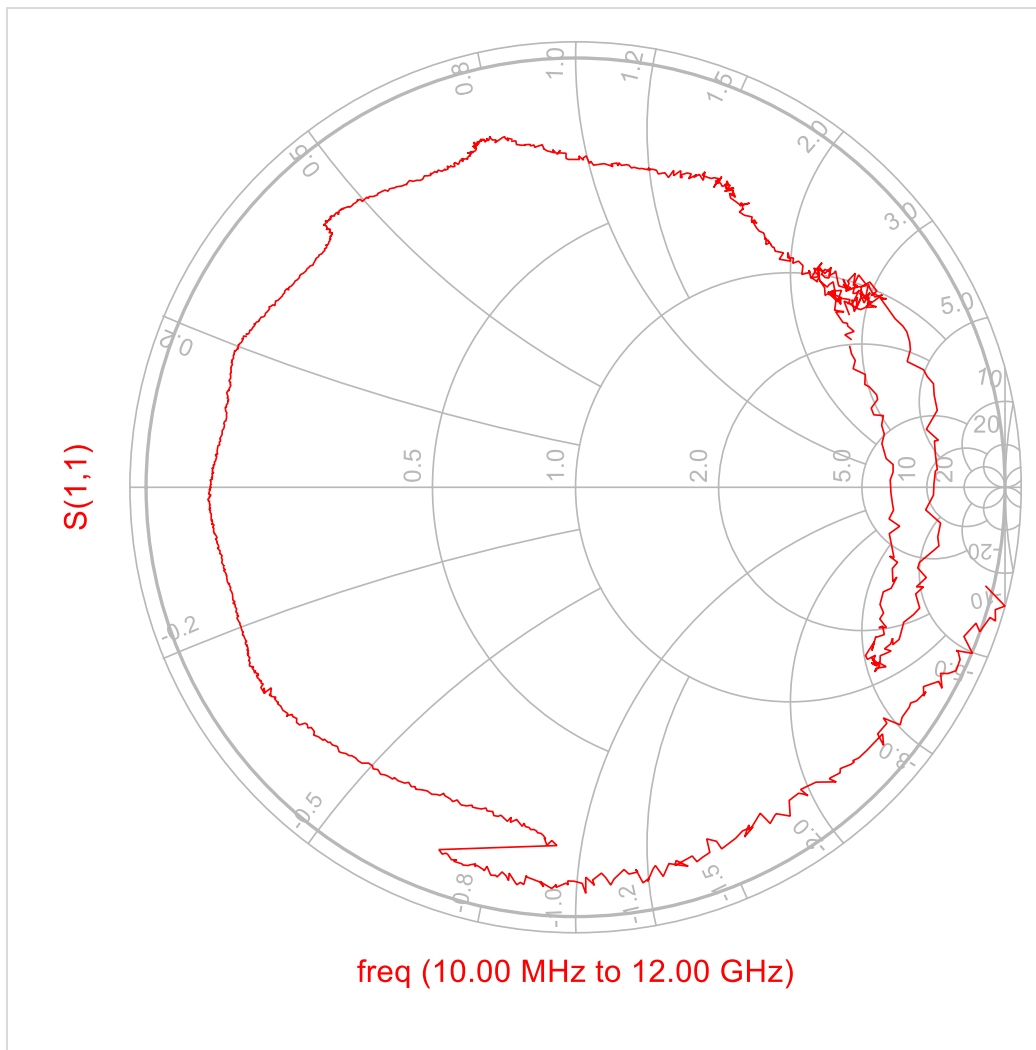

Typical Operating Curves: Single-Tone, $V_{DS} = 40\text{ V}$, $I_{DQ} = 12\text{ mA}$

Broadband S-Parameters (Mag-dB)

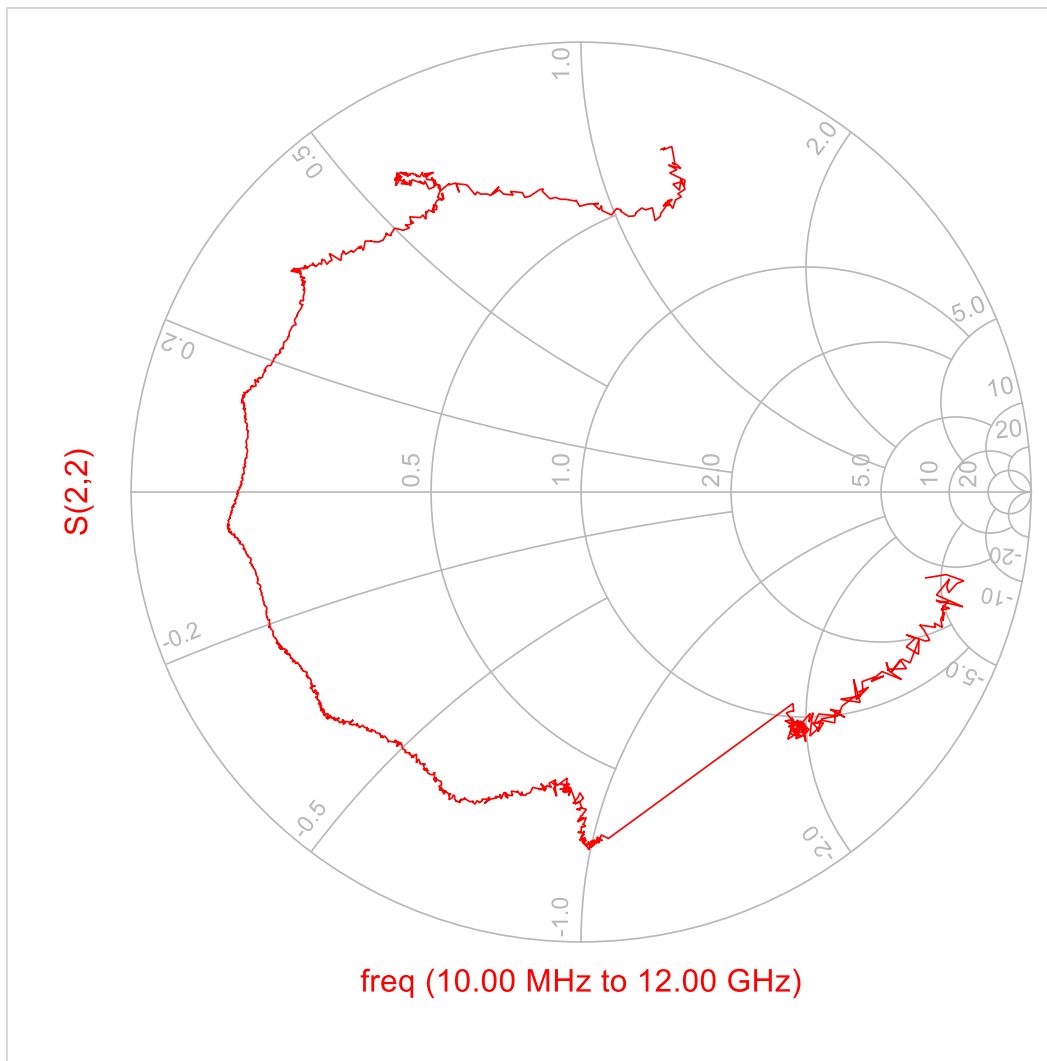

Typical Operating Curves: 2.7 to 3.2 GHz, 40 V, 20 mA, Pulsed CW (10% duty cycle, 100 µs pulse width)

Gain vs. Output Power and Frequency

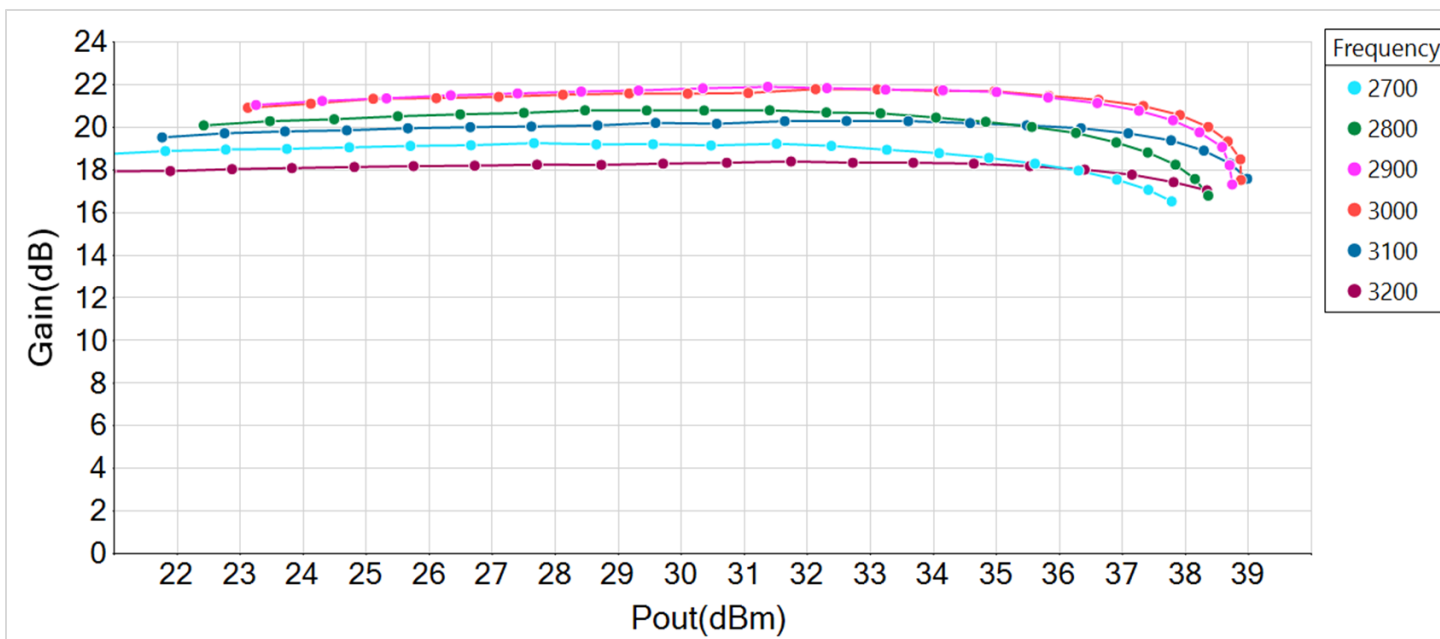

Drain Efficiency vs. Output Power and Frequency

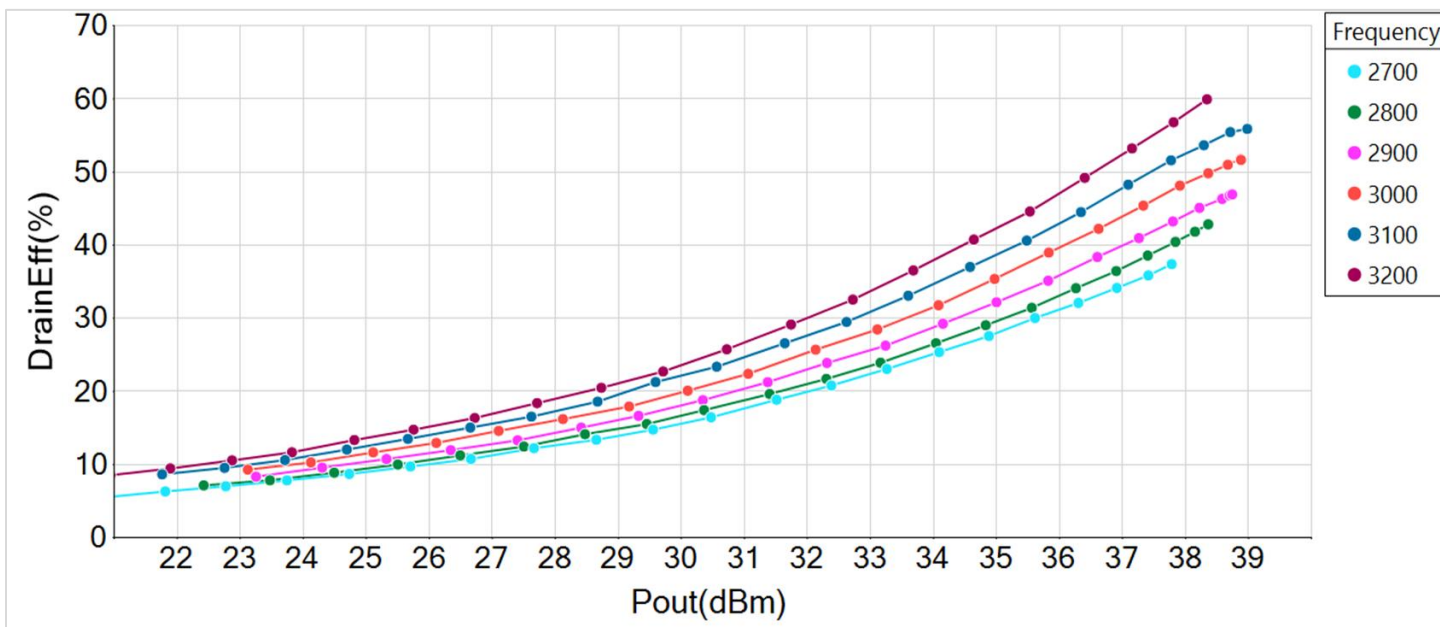

Typical Operating Curves: 2.7 to 3.2 GHz, 40 V, 20 mA, Pulsed CW (10% duty cycle, 100 µs pulse width)

Gain vs. Frequency (2.5 dB Compression)

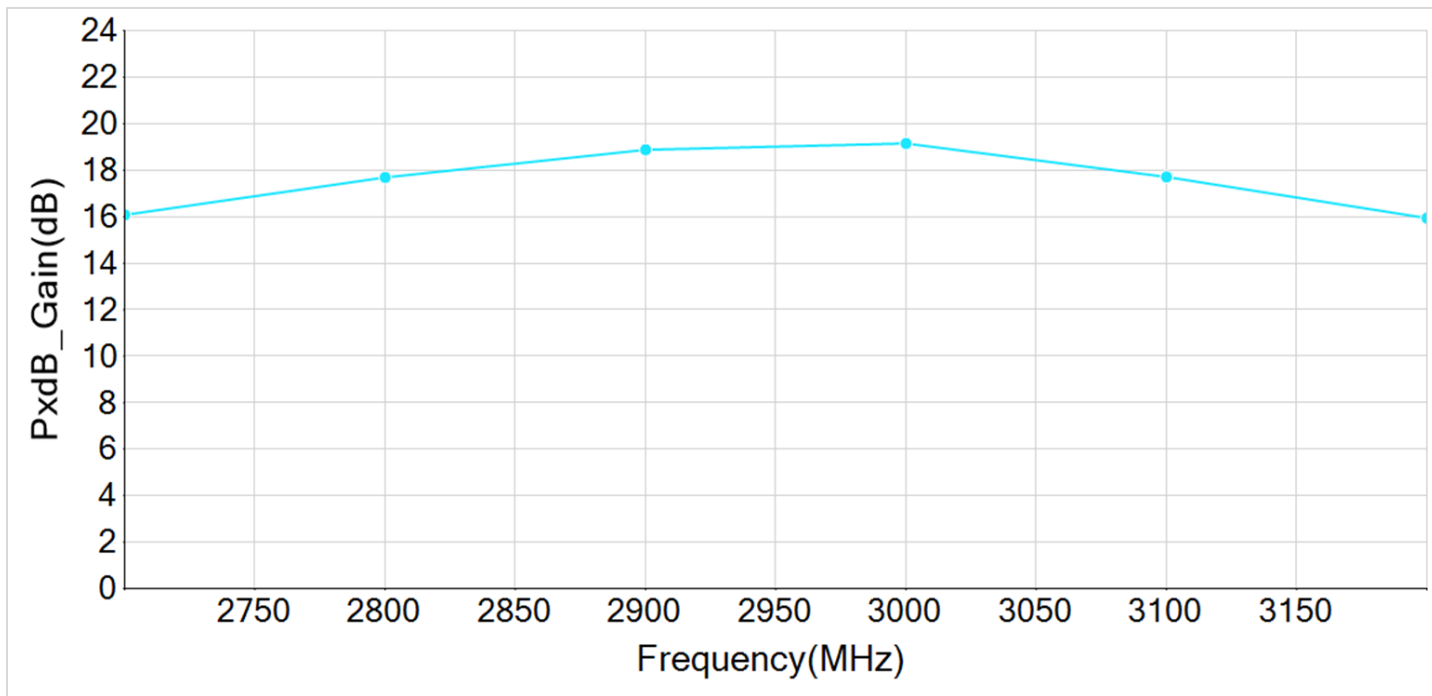

P_{OUT} vs. Frequency (2.5 dB Compression)

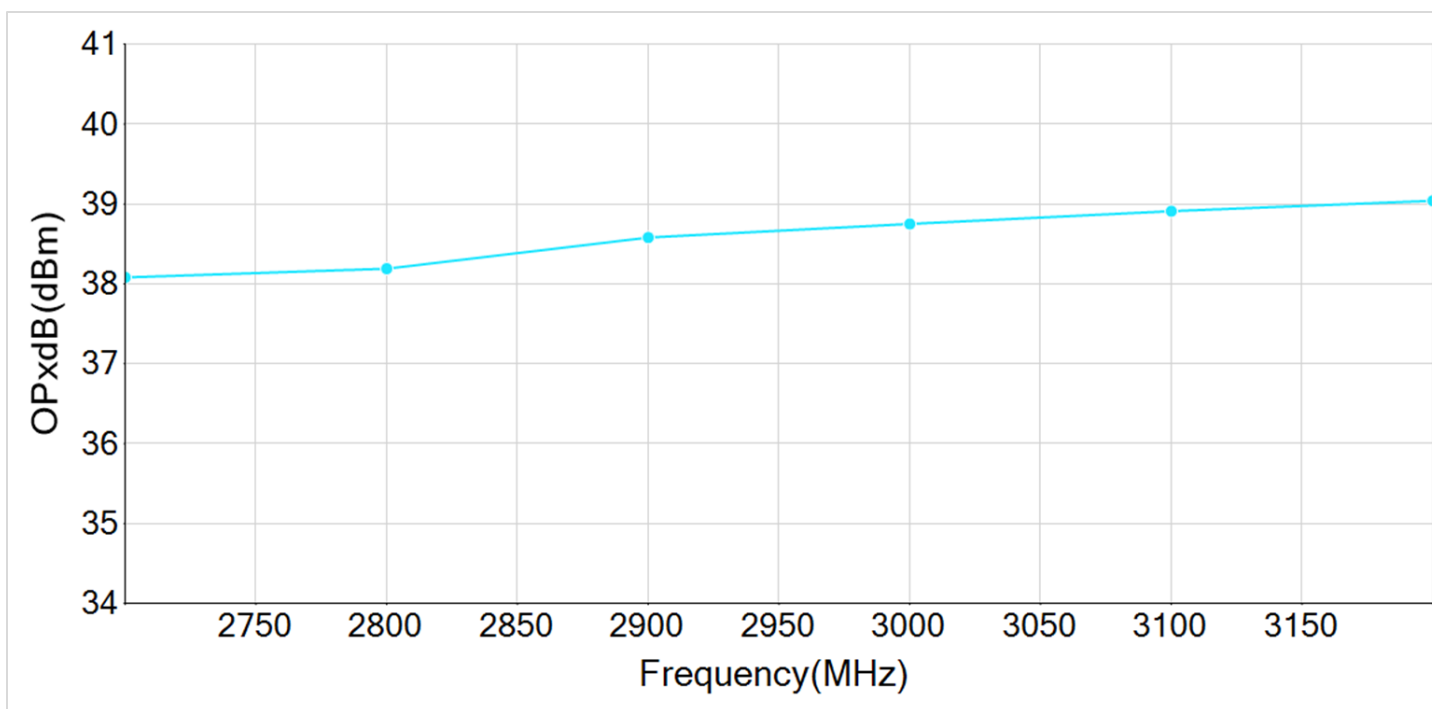

Typical Operating Curves: 2.7 to 3.2 GHz, 40 V, 20 mA, Pulsed CW (10% duty cycle, 100 µs pulse width)

Drain Efficiency vs. Frequency (2.5 dB Compression)

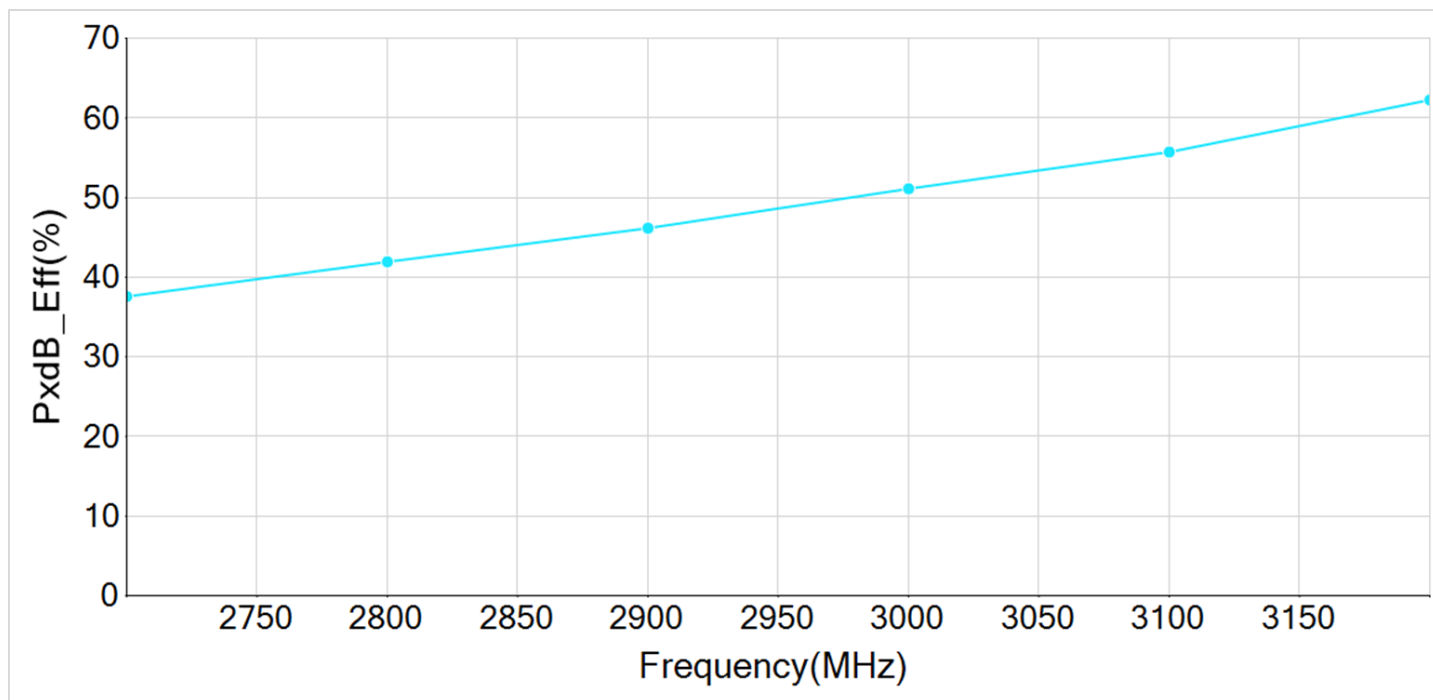

GRF0005 Evaluation Board Assembly Diagram

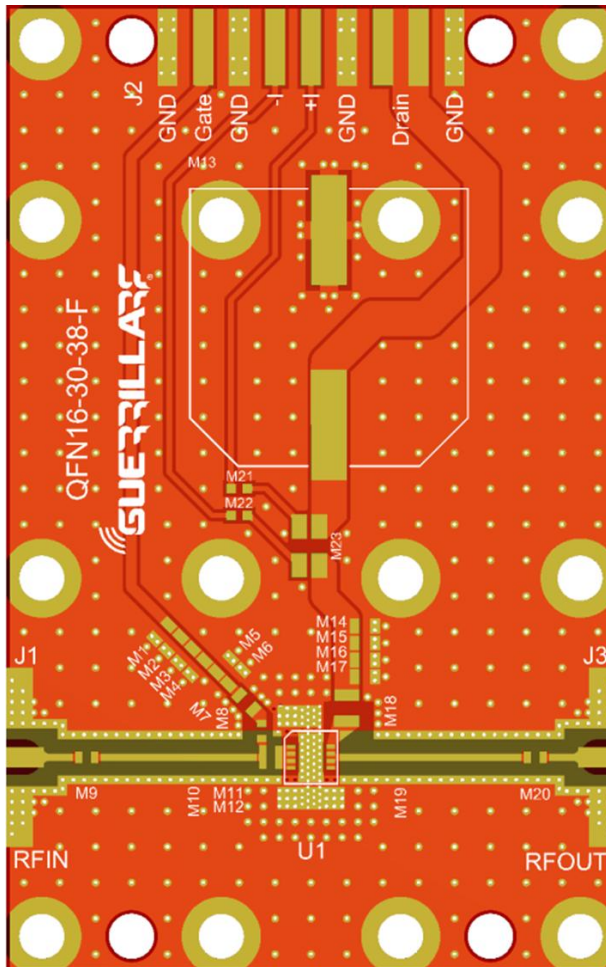

RF Component Placement

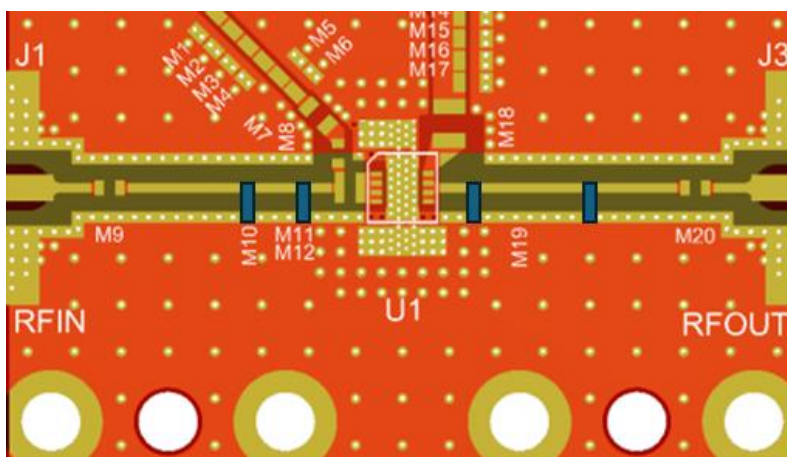

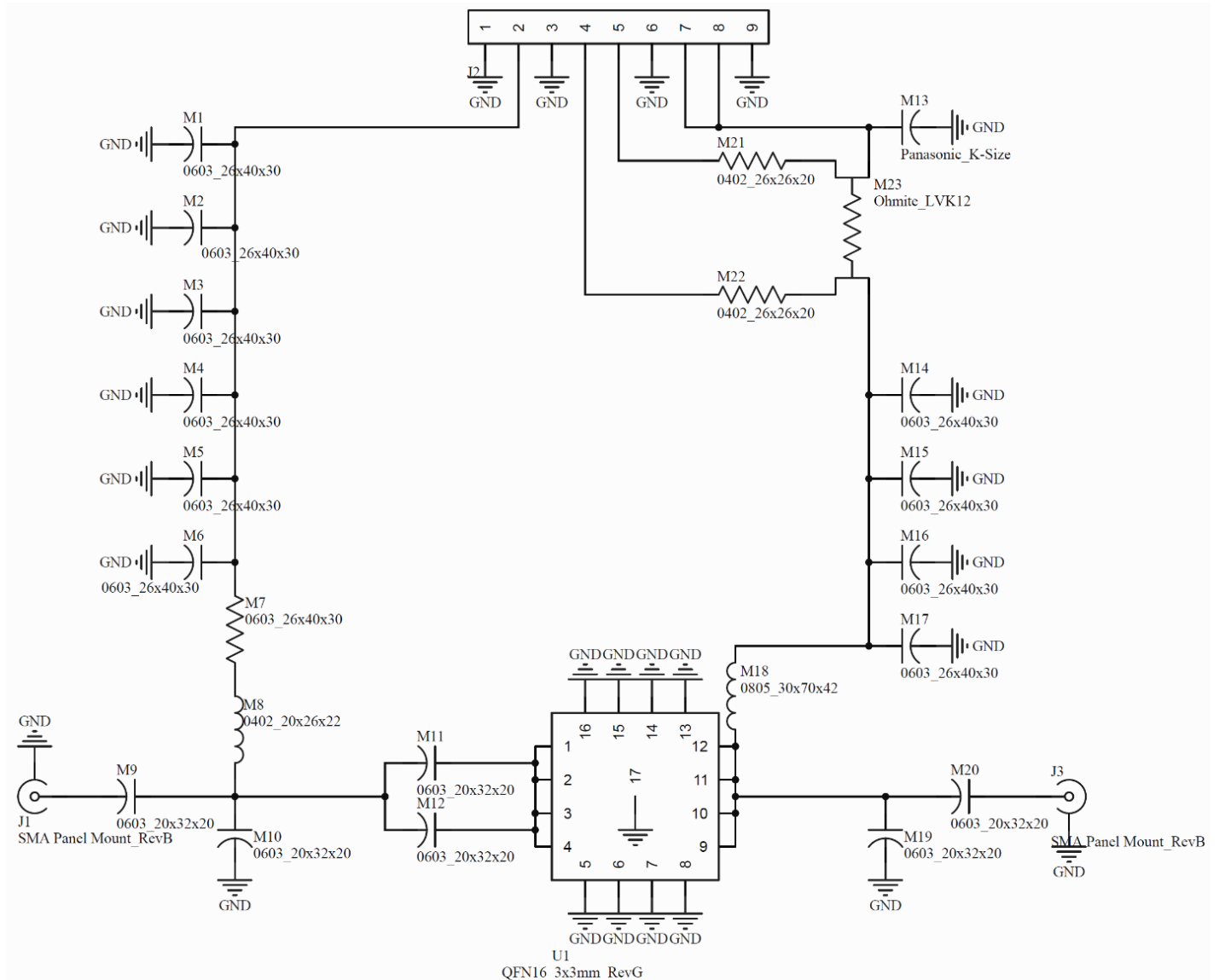

GRF0005 Standard Evaluation Board Schematic

GRF0005 Evaluation Board Assembly Diagram Reference: 2.7 to 3.2 GHz Tune

Component	Type	Manufacturer	Family	Value	Package Size	Substitution
M1, M2	Capacitor	Murata	GQM	10 μ F	0603	ok
M3, M14	Capacitor	Murata	GQM	1.0 μ F	0603	ok
M4, M15	Capacitor	Murata	GQM	1000 pF	0603	ok
M5, M16	Capacitor	Murata	GQM	100 pF	0603	ok
M6, M9, M17	Capacitor	Murata	GQM	10 pF	0603	ok
M7	Inductor	Murata	LQW	6.8 nH	0402	ok
M8	Resistor	Various	5%	0 Ω	0402	ok
M10.	Capacitor	Murata	GQM	0.5 pF / 2.0 pF	0603	ok
M11	Resistor	Various	5%	2 Ω	0402	ok
M12	DNP	--	--	--	--	--
M13	Electrolytic Capacitor	Various	N/A	220 μ F	12.5 mm	ok
M18	Inductor	Murata	LQW	3.2 nH	0805	ok
M19	Capacitor	Murata	GQM	0.1 pF / 1.0 pF	0603	ok
M20	Capacitor	Murata	GQM	8.2 pF	0603	ok
M21/M22	Resistor	Various	5%	1k Ω	0603	ok
M23	Resistor	Ohmite	5%	10 M Ω	1206	ok
J1, J3	SMA Connector	Various	--	--	--	--
J2	DC Connector	Various	--	--	--	--
Evaluation Board	QFN16-30-38-F	--	--	--	--	--

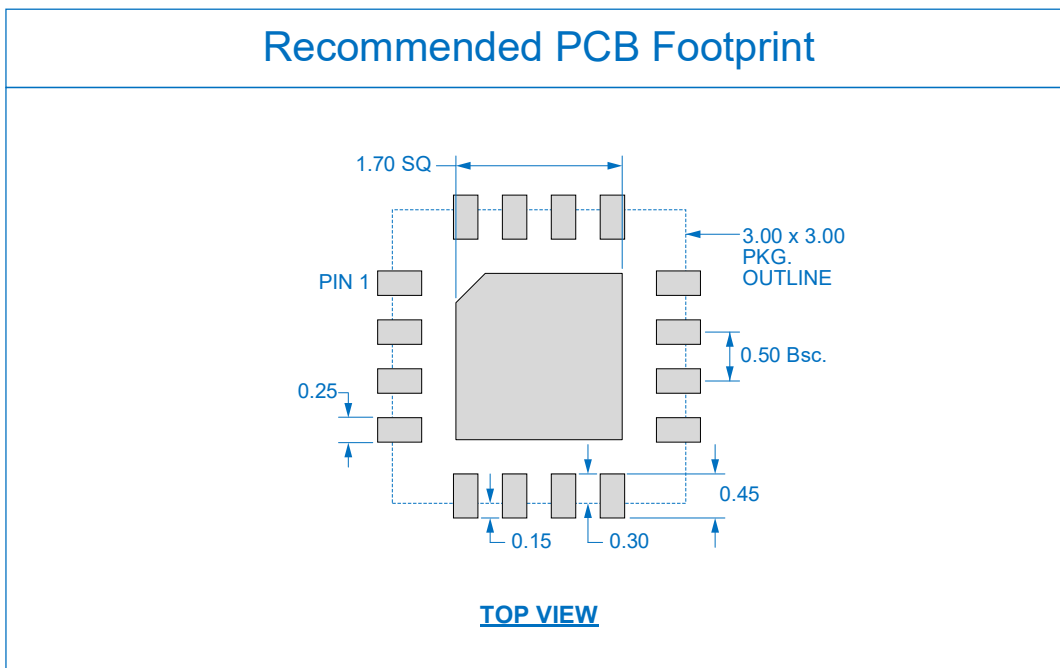
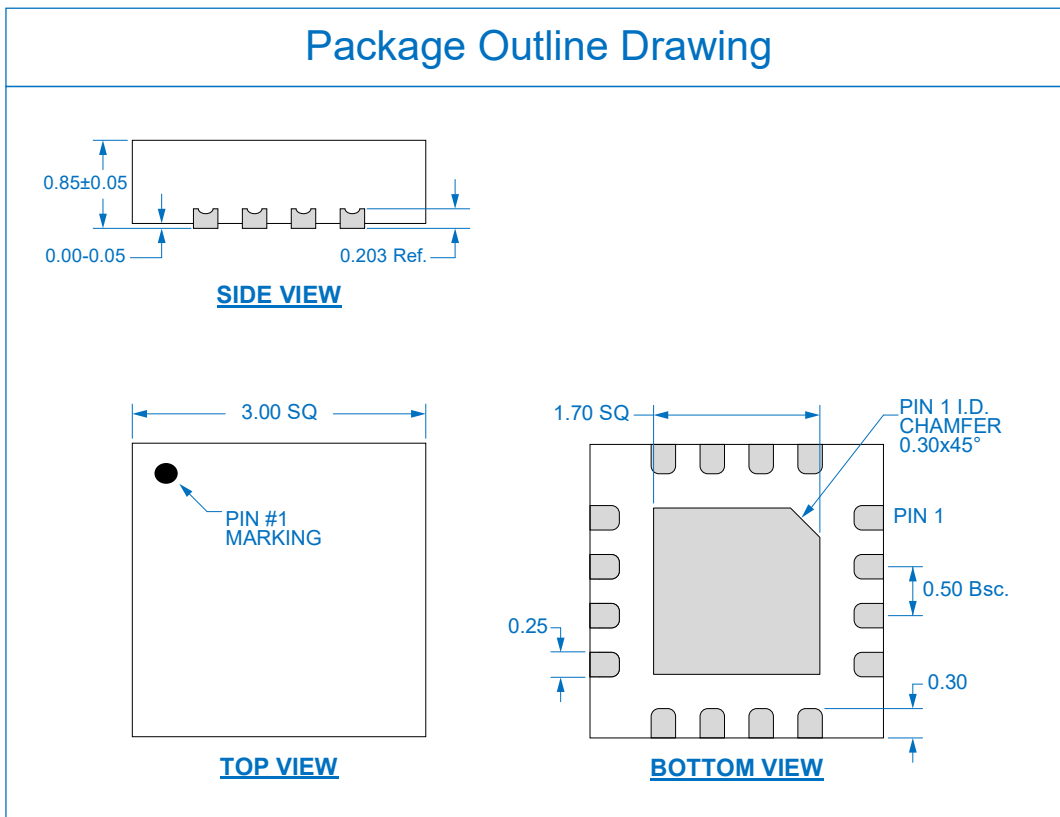

QFN-16 3 x 3 Package Dimensions and Suggested PCB Footprint (Top View)

Package Marking Diagram



- Line 1: "YY" = YEAR. "WW" = WORK WEEK the device was assembled.
- Line 2: "GRF" = Guerrilla RF.
- Line 3: "XXXX" = Device PART NUMBER.

Tape and Reel Information

Guerrilla RF's tape and reel specification complies with Electronic Industries Alliance (EIA) standards for "Embossed Carrier Tape of Surface Mount Components for Automatic Handling" (reference EIA-481). See the following page for the Tape and Reel Specification and Device Package Information table, which includes units per reel.

Devices are loaded with pins down into the carrier pocket with protective cover tape and reeled onto a plastic reel. Each reel is packaged in a cardboard box. There are product labels on the reel, the protective ESD bag and the outside surface of the box.

For the Tape and Reel Reference Table, please refer to: <https://www.guerrilla-rf.com/prodFiles/Manufacturing/MN001.pdf>

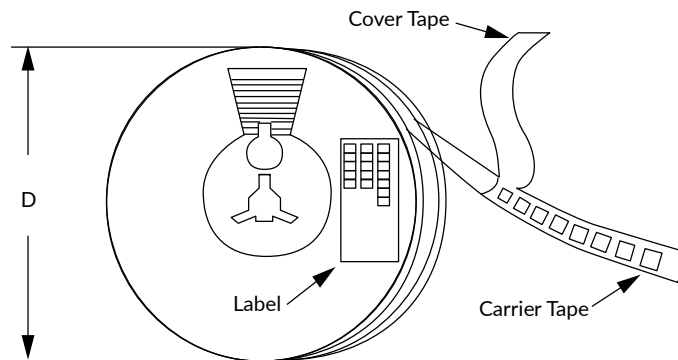

Tape and Reel Packaging with Reel Diameter Noted (D)

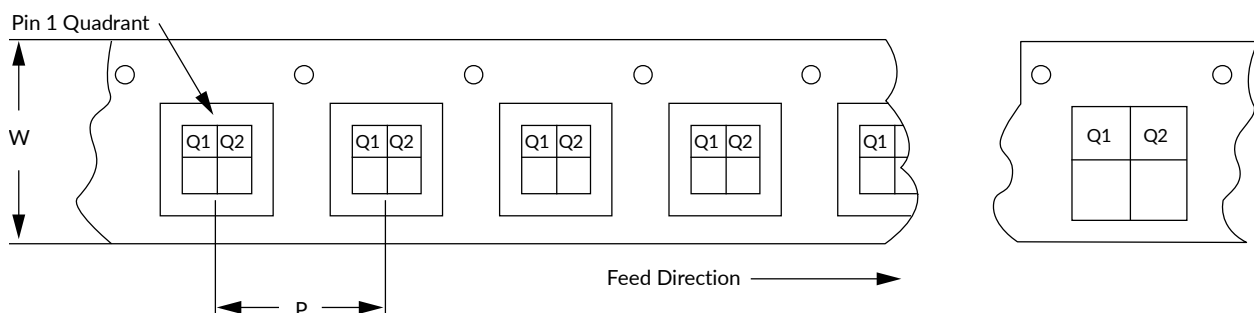

Carrier Tape Width (W), Pitch (P), Feed Direction and Pin 1 Quadrant Information



Revision History

Revision Date	Description of Change
May 20, 2025	Preliminary Data Sheet.
November 17, 2025	Added new S-parameter plots.
March 5, 2026	Release Ø Data Sheet. Updated specifications. Added evaluation board schematic.



Data Sheet Classifications

Data Sheet Status	Notes
Advance	S-Parameter and NF data based on EM simulations for the fully packaged device using foundry-supplied transistor S-Parameters. Linearity estimates based on device size, bias condition and experience with related devices.
Preliminary	All data based on limited evaluation board measurements taken within the Guerrilla RF Applications Lab. All parametric values are subject to change pending the collection of additional data.
Release Ø	All data based on measurements taken with <i>production-released</i> material. TYP values are based on a combination of ATE and bench-level measurements, with MIN/MAX limits defined using <i>modelled estimates</i> that account for part-to-part variations and expected process spreads. Although unlikely, future refinements to the TYP/MIN/MAX values may be in order as multiple lots are processed through the factory.
Release A-Z	All data based on measurements taken with production-released material <i>derived from multiple lots which have been fabricated over an extended period of time</i> . MIN/MAX limits may be refined over previous releases as more statistically significant data is collected to account for process spreads.

Information in this data sheet is specific to the Guerrilla RF, Inc. ("Guerrilla RF") product identified.

This data sheet, including the information contained in it, is provided by Guerrilla RF as a service to its customers and may be used for informational purposes only by the customer. Guerrilla RF assumes no responsibility for errors or omissions on this data sheet or the information contained herein. Information provided is believed to be accurate and reliable, however, no responsibility is assumed by Guerrilla RF for its use, nor for any infringement of patents, or other rights of third parties, resulting from its use. Guerrilla RF assumes no liability for any data sheet, data sheet information, materials, products, product information, or other information provided hereunder, including the sale, distribution, reproduction or use of Guerrilla RF products, information or materials.

No license, whether express, implied, by estoppel, by implication or otherwise is granted by this data sheet for any intellectual property of Guerrilla RF, or any third party, including without limitation, patents, patent rights, copyrights, trademarks and trade secrets. All rights are reserved by Guerrilla RF.

All information herein, products, product information, data sheets, and data sheet information are subject to change and availability without notice. Guerrilla RF reserves the right to change component circuitry, recommended application circuitry and specifications at any time without prior notice. Guerrilla RF may further change its data sheet, product information, documentation, products, services, specifications or product descriptions at any time, without notice. Guerrilla RF makes no commitment to update any materials or information and shall have no responsibility whatsoever for conflicts, incompatibilities, or other difficulties arising from any future changes.

GUERRILLA RF INFORMATION, PRODUCTS, PRODUCT INFORMATION, DATA SHEETS AND DATA SHEET INFORMATION ARE PROVIDED "AS IS" AND WITHOUT WARRANTY OF ANY KIND, WHETHER EXPRESS, IMPLIED, STATUTORY, OR OTHERWISE, INCLUDING FITNESS FOR A PARTICULAR PURPOSE OR USE, MERCHANTABILITY, PERFORMANCE, QUALITY OR NON-INFRINGEMENT OF ANY INTELLECTUAL PROPERTY RIGHT; ALL SUCH WARRANTIES ARE HEREBY EXPRESSLY DISCLAIMED. GUERRILLA RF DOES NOT WARRANT THE ACCURACY OR COMPLETENESS OF THE INFORMATION, TEXT, GRAPHICS OR OTHER ITEMS CONTAINED WITHIN THESE MATERIALS. GUERRILLA RF SHALL NOT BE LIABLE FOR ANY DAMAGES, INCLUDING BUT NOT LIMITED TO ANY SPECIAL, INDIRECT, INCIDENTAL, STATUTORY, OR CONSEQUENTIAL DAMAGES, INCLUDING WITHOUT LIMITATION, LOST REVENUES OR LOST PROFITS THAT MAY RESULT FROM THE USE OF THE MATERIALS OR INFORMATION, WHETHER OR NOT THE RECIPIENT OF MATERIALS HAS BEEN ADVISED OF THE POSSIBILITY OF SUCH DAMAGE.

Customers are solely responsible for their use of Guerrilla RF products in the Customer's products and applications or in ways which deviate from Guerrilla RF's published specifications, either intentionally or as a result of design defects, errors, or operation of products outside of published parameters or design specifications. Customers should include design and operating safeguards to minimize these and other risks. Guerrilla RF assumes no liability or responsibility for applications assistance, customer product design, or damage to any equipment resulting from the use of Guerrilla RF products outside of stated published specifications or parameters.